

# POWER MOLLER<sup>®</sup> 24!

## Brushless DC Motor Driver [CBM-105 FN/FP] User Manual

Thank you for purchasing a Itoh Denki CBM-105 series motor driver.  
Please read this manual before operating the product,  
and keep this manual readily accessible for reference.



### Applicable Power Moller (MDR) models:

PM486FE, PM486FP, PM486FS, PM500FE  
PM500FP, PM570FE, PM605FE, PMT42FE

\*BR(Brake) and LT(Low temperature) is not available on CBM-105

MDR (Motor Driven Roller)

MDR is DC brushless motorized roller for conveyor.  
MDR is defined by Conveyor Equipment Manufacturers  
Association (CEMA) and conveyor built by MDR is well  
established technology in Material Handling Industry.



No.561

### INDEX

1. Safety Instructions	(1)
2. Power	(1)
3. Before Operating the Product	
3-1. Mounting	(1)
3-2. Wiring	(1) ~ (2)
3-3. Direction Setting	(2)
4. Functions	(2) ~ (3)
5. Operation Instruction	
5-1. Speed Variation	(3)
5-1-1. Internal Speed Variation	(3) ~ (5)
5-1-2. External Speed Variation	(3) ~ (5)
5-2. Direction Setting	(6)
5-3. Acceleration and Deceleration	(6)
6. Error Signal Output	(6)
7. Motor Plus Signal Output	(7)
8. Error Status, Reset, History	(7) ~ (8)
9. Servo Brake	(8)
10. Troubleshooting	(9)
11. Dimension	(10)
12. Product specifications	(10)

### Standard Accessories

- Power Connector (CN1) ——— ×1
- Control Connector(CN2) ——— ×1
- Mounting screws and nut
- Screw : M4×15 ——— ×2
- Nut : M4 ——— ×2

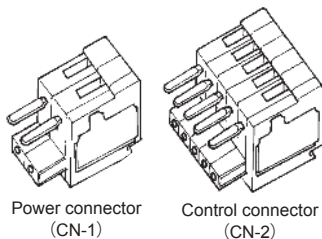

## 1. Safety Instructions

- Switch off the power, when removing from conveyor, wiring or maintenance is done, otherwise you have a risk of electrical shock or injury
- Respect the electrical regulations of the site or equipment, where the product is installed. (Labor safety and sanitary regulations, electrical equipment technical standard, etc)
- Operate the motor driver within its intended design and specifications to avoid electrical shock, injury or fire.
- Do not disassemble, repair nor modify the product (For which we do not warrant) It might cause electrical shock, injury or failure.
- Separately set the circuitry to monitor the important input and/or output signal status, which might cause accident, because the signal may stay ON or OFF in case of the CBM-105 driver card failure.
- Be sure to shut off the power before inserting or removing any connector. Do not wire connector left in the CBM-105 driver card.
- Do not drop, give external impact nor pressure to the CBM-105 driver card. If that happened, do not reuse it.
- Make sure all the connectors are properly engaged with cables.
- Make sure the conveyor frame and control box where the CBM-105 driver card is mounted are grounded.
- Do not switch ON or OFF the relay or contractor in close proximity to power or signal line, or the CBM-10 driver card as the generated noise could cause malfunction.
- Be sure to inject power or input signal for 15msec or over to ensure the proper reaction.
- Do not remove any connector during operation. It may cause of damage to the driver card or shorten its life time.
- Do not shut power off during MDR is running. It may cause of damage to the driver card or shorten its life time.
- Do not get on the conveyor if power is ON to the driver cards. Do not turn on power, if totes are not steady on conveyor. It might cause electrical shock, injury or failure.
- Do not pull by force the Power Moller to turn.  
It may cause of damage to driver card or shorten its life cycle.
- Without power on to the driver card, dynamic brake or servo brake is not worked.

## 2. Power

- DC24V battery
- Switching power (24VDC 5A) or smoothed and rectified power
- Smoothed and rectified power (≤ 10% ripple)
- ※Use stable power supply with 5A or over. The power supply should not be affected by peak current 20A for 1msec.

## 3. Before Operating the Product

### 3-1. Mounting

- ① Make mounting holes in the conveyor frame to fit the fixing holes in the product.  
(See Dimensions in section 11)  
※The product's back place should be paid to prevent the metallic dust entry to the product.  
※Make sure the conveyor us adequately grounded.
- ② Fix the product tightly to the conveyor frame with the supplied mounting screws and nuts with the recommended fastening torque between 1.5Nm and 1.9Nm.

### 3-2. Wiring

- Wiring should be made while the product is not powered.
- Switch for Run/Stop or CW/CCW is an option and is not supplied.
- Relay contact or PLC output is available instead of the above switch.
- Wiring to the supplied connectors should be made before inserting into the driver.

#### [Wiring diagram]

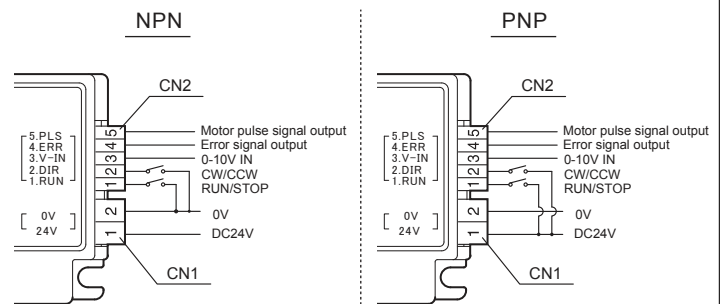

#### CN2

- 1 MDR run and stop (Mandatory) → See section 5
- 2 MDR direction (CW/CCW)\* → See section 5-2  
\*Turning direction setting can also be done by dip switch on the PCB.
- 3 External speed variation by analog voltage change → See section 5-1  
\*Speed variation setting also can be done by Rotary Switch on the PCB.
- 4 Discharge of error signal → See section 6
- 5 Discharge of motor pulse → See section 7

① Wire 24VDC and 0V to the Power Connector CN1(2P)

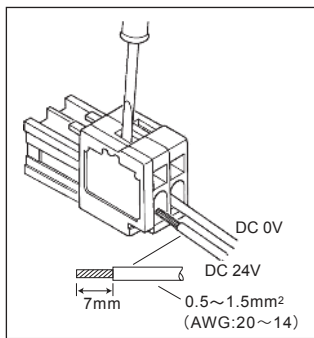

- ※ Connector current capacity is 10A. Avoid wiring causing excessive current.
- ※ Make sure the +/- wiring is correct.
- ※ Wiring should be made before inserting into the driver card.
- ※ Connecting with external device such as Relay Coil requires apply coil surge absorption type or add protective devices to protect from surge otherwise remote OUTPUT in CBM-105 may be damaged by back EMF when output signal is changed.

② Wire to the Control Connector CN2 (5P) per the diagram in section 3.

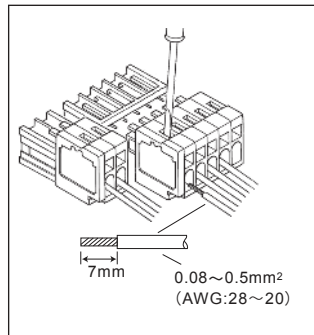

- ※ 0V to CN2-1(Run/Stop) and CN2-2 (CW/CCW) should be common to the power voltage. (Connector current capacity is 4A)
- ※ Analog voltage input to CN2-3(External voltage) should not exceed 10V. 0V should be common to the power voltage.
- ※ CN2-4(Error signal output) can be selected by SW1-6.
- ※ Connecting with external device such as Relay Coil requires apply coil surge absorption type or add protective devices to protect from surge otherwise remote OUTPUT in CBM-105 may be damaged by back EMF when output signal is changed.

SW1-6	Error signal output
ON	PNP Open collector
OFF	NPN Open collector

- ※ Motor Pulse signal from CN2-5 is NPN Open collector.

③ Insert the pre-wired Power connector CN1, Control connector CN2 and Motor connector respectively to the counter connectors in the driver card. (Motor connector to CN3) while the power is shut off.

### 3-3. Direction Setting

Motor direction can be changed by SW1-3 or CN2-2. →See section 5-2  
 ※The setting differs according to the Power Moller model. Check the model from the circular label put on the Power Moller end housing.

Model nomenclature

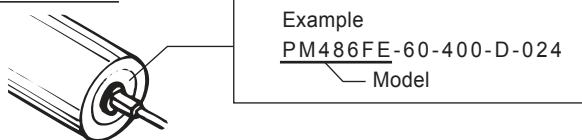

### 4. Function

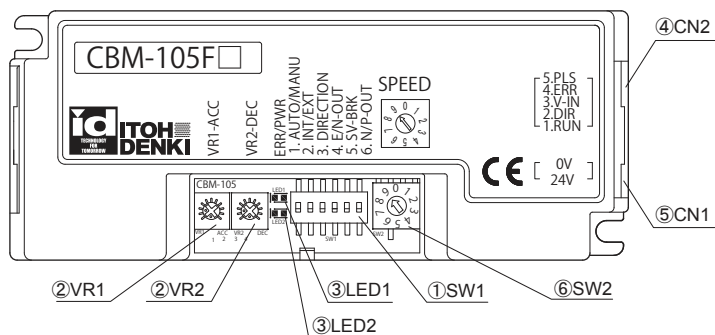

① Dip Switch (SW1)

No	Function	ON	OFF	Default	Remarks
1	Thermister / Low Voltage / Back EMF Auto Reset / Manual Reset	Manual	Automatic	ON	See section8
2	Speed variation	External	Internal	OFF	See section 5-1
3	Direction	See section 5-2		OFF	See section 5-2
4	Error signal	Discharged in normal status	Discharged in error stats	OFF	See section 6
5	Brake Type	Servo	Dynamic	OFF	See section 9
6	Error signal output type	PNP	NPN	※	See section 6

※ In case of CBM-105FN; Default setting on SW1-6 is OFF  
 In case of CBM-105PN; Default setting on SW1-6 is ON

② Potentiometer (VR)

		Min (To the CCW end)	Max (To the CW end)	Default	Remarks
1	Acceleration from RUN signal	0 sec	2.5 sec	Min	See section 5-3
2	Deceleration from STOP signal	0 sec	2.5 sec	Min	

③ LED

	Color	Status	Remarks
1	Green	Powered and functions normally	See section8
2	Red	Indicates type of error	

④ Control Connector (CN2)

	Function	Remarks
5	Motor pulse signal output	See section 7
4	Error signal output	See section 6
3	External speed variation	See section 5-1
2	Motor turning direction	See section 5-2
1	Motor RUN/STOP	See section 5

⑤ Power Connector (CN1)

2	0V
1	DC24V

⑥ SW2

10 index speed setting  
 (※20 index speed setting on external speed function)

## 5. Operation Instructions

Ensure the following before operating the product

- Power Moller is adequately installed in compliance with the manual.
- Power Moller shafts are adequately secured with the supplied brackets or accessories.
- Each connector on the driver card is adequately wired and inserted.
- Operating and environmental conditions are respected.
- Power supply has sufficient capacity (Stable 24VDC, 5A or over) so as not to be affected by varying load
- The protector for the power supply should not react with peak current 20A 1msec or less.

① Supply 24VDC to the driver card, and the LED1(Green) illuminates.

② Close the contact of CN2-1, and the Power Moller starts running.

- 0V should be common to the power voltage.
- 7.3mA current is drawn to CN2-1.
- Wait 1sec after the driver card is powered before running Power Moller.

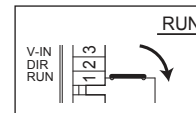

③ Open the contact of CN2-1, and the Power Moller stops.

- Power Moller run/stop should be manipulated only by CN2-1 and 0V, not by the 24VDC power to the driver card.

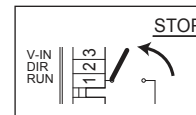

④ To vary the motor speed, follow the section 5-1.

⑤ To reverse the motor, follow the section 5-2.

⑥ To accelerate or decelerate the motor, follow the section 5-3.

### 5-1. Speed Variation

Speed of the Power Moller can be varied either internally by internal Rotary Switch (SW2) or externally by analog voltage input(CN2).

- Range of speed variation differs according to the Power Moller model. Check the nominal speed of the model from the circular label put on its end housing.

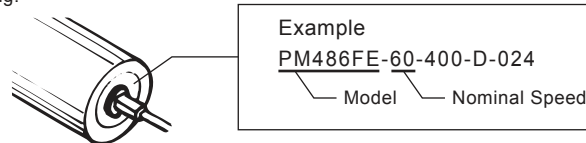

[5-1-1. Internal Speed Variation]

- ①Set the SW1-2 OFF to effect the internal speed variation.
- ②Speed can be varied by Rotary Switch(SW2) in 10steps.

[5-1-2. External Speed Variation]

- ①Set the SW1-2 ON to effect the external speed variation.
- ②Inject and vary the analog voltage between 0V and 10V to CN2-3 to vary the motor speed in 20steps.
  - ※Max 2mA current is consumed at CN2-3.
  - ※The analog voltage input should not exceed 10V. Its 0V should be common to the Power Voltage.

**PM486FE**

Speed deviation : ±3%

Internal speed variation	Power Moller Rated Speed (m/min)			Analog voltage input
	SW2	Type 210	Type 60	
9	184.9	52.0	14.6	9.6~9.9
8	184.9	52.0	14.6	9.1~9.4
-	184.9	52.0	14.6	8.6~8.9
7	177.8	50.0	14.1	8.1~8.4
-	168.9	47.5	13.4	7.6~7.9
6	160.0	45.0	12.7	7.1~7.4
5	142.2	40.0	11.2	6.6~6.9
-	133.3	37.5	10.5	6.1~6.4
-	124.4	35.0	9.8	5.6~5.9
-	115.6	32.5	9.1	5.1~5.4
4	106.7	30.0	8.4	4.6~4.9
-	97.8	27.5	7.7	4.1~4.4
-	88.9	25.0	7.0	3.6~3.9
-	80.0	22.5	6.3	3.1~3.4
3	71.1	20.0	5.6	2.6~2.9
-	62.2	17.5	4.9	2.1~2.4
2	53.3	15.0	4.2	1.6~1.9
-	44.4	12.5	3.5	1.1~1.4
1	35.6	10.0	2.8	0.6~0.9
0	26.7	7.5	2.1	0.1~0.4

**PM486FP**

Speed deviation : ±3%

Internal speed variation	Power Moller Rated Speed (m/min)			Analog voltage input
	SW2	Type 255	Type 55	
9	243.7	53.5	14.2	9.6~9.9
8	243.7	53.5	14.2	9.1~9.4
-	243.7	53.5	14.2	8.6~8.9
7	243.7	53.5	14.2	8.1~8.4
-	235.1	51.6	13.7	7.6~7.9
6	222.8	48.9	13.0	7.1~7.4
5	197.7	43.4	11.5	6.6~6.9
-	185.4	40.7	10.8	6.1~6.4
-	173.1	38.0	10.1	5.6~5.9
-	160.8	35.3	9.4	5.1~5.4
4	148.5	32.6	8.6	4.6~4.9
-	136.2	29.9	7.9	4.1~4.4
-	123.5	27.1	7.2	3.6~3.9
-	111.2	24.4	6.5	3.1~3.4
3	98.9	21.7	5.7	2.6~2.9
-	86.6	19.0	5.0	2.1~2.4
2	74.3	16.3	4.3	1.6~1.9
-	62.0	13.6	3.6	1.1~1.4
1	49.7	10.9	2.9	0.6~0.9
0	36.9	8.1	2.1	0.1~0.4

**PM500FE**

Speed deviation : ±3%

Internal speed variation	Power Moller Rated Speed (m/min)			Analog voltage input
	SW2	Type 210	Type 60	
9	190.2	53.5	15.0	9.6~9.9
8	190.2	53.5	15.0	9.1~9.4
-	190.2	53.5	15.0	8.6~8.9
7	182.9	51.4	14.5	8.1~8.4
-	173.8	48.9	13.7	7.6~7.9
6	164.6	46.3	13.0	7.1~7.4
5	146.3	41.2	11.6	6.6~6.9
-	137.2	38.6	10.9	6.1~6.4
-	128.0	36.0	10.1	5.6~5.9
-	118.9	33.4	9.4	5.1~5.4
4	109.7	30.9	8.7	4.6~4.9
-	100.6	28.3	8.0	4.1~4.4
-	91.5	25.7	7.2	3.6~3.9
-	82.3	23.1	6.5	3.1~3.4
3	73.2	20.6	5.8	2.6~2.9
-	64.0	18.0	5.1	2.1~2.4
2	54.9	15.4	4.3	1.6~1.9
-	45.7	12.9	3.6	1.1~1.4
1	36.6	10.3	2.9	0.6~0.9
0	27.4	7.7	2.2	0.1~0.4

Consult local ITOH DENKI representative in case you use Power Moller with nominal speed not in the above table.

**PM500FP**

Speed deviation : ±3%

Internal speed variation	Power Moller Rated Speed (m/min)			Analog voltage input
	SW2	Type 255	Type 55	
9	250.7	55.0	14.6	9.6~9.9
8	250.7	55.0	14.6	9.1~9.4
-	250.7	55.0	14.6	8.6~8.9
7	250.7	55.0	14.6	8.1~8.4
-	241.8	53.1	14.1	7.6~7.9
6	229.2	50.3	13.3	7.1~7.4
5	203.4	44.7	11.8	6.6~6.9
-	190.8	41.9	11.1	6.1~6.4
-	178.1	39.1	10.4	5.6~5.9
-	165.4	36.3	9.6	5.1~5.4
4	152.8	33.5	8.9	4.6~4.9
-	140.1	30.8	8.1	4.1~4.4
-	127.0	27.9	7.4	3.6~3.9
-	114.4	25.1	6.6	3.1~3.4
3	101.7	22.3	5.9	2.6~2.9
-	89.0	19.5	5.2	2.1~2.4
2	76.4	16.8	4.4	1.6~1.9
-	63.7	14.0	3.7	1.1~1.4
1	51.1	11.2	3.0	0.6~0.9
0	38.0	8.3	2.2	0.1~0.4

**PM570FE**

Speed deviation : ±3%

Internal speed variation	Power Moller Rated Speed (m/min)			Analog voltage input
	SW2	Type 210	Type 60	
9	216.8	61.0	17.2	9.6~9.9
8	216.8	61.0	17.2	9.1~9.4
-	216.8	61.0	17.2	8.6~8.9
7	208.5	58.6	16.5	8.1~8.4
-	198.1	55.7	15.7	7.6~7.9
6	187.7	52.8	14.8	7.1~7.4
5	166.8	46.9	13.2	6.6~6.9
-	156.4	44.0	12.4	6.1~6.4
-	146.0	41.0	11.5	5.6~5.9
-	135.5	38.1	10.7	5.1~5.4
4	125.1	35.2	9.9	4.6~4.9
-	114.7	32.3	9.1	4.1~4.4
-	104.3	29.3	8.2	3.6~3.9
-	93.8	26.4	7.4	3.1~3.4
3	83.4	23.5	6.6	2.6~2.9
-	73.0	20.5	5.8	2.1~2.4
2	62.6	17.6	4.9	1.6~1.9
-	52.1	14.7	4.1	1.1~1.4
1	41.7	11.7	3.3	0.6~0.9
0	31.3	8.8	2.5	0.1~0.4

**PM605FE**

Speed deviation : ±3%

Internal speed variation	Power Moller Rated Speed (m/min)			Analog voltage input
	SW2	Type 210	Type 60	
9	230.2	64.7	18.2	9.6~9.9
8	230.2	64.7	18.2	9.1~9.4
-	230.2	64.7	18.2	8.6~8.9
7	221.3	62.2	17.5	8.1~8.4
-	210.2	59.1	16.6	7.6~7.9
6	199.2	56.0	15.8	7.1~7.4
5	177.0	49.8	14.0	6.6~6.9
-	166.0	46.7	13.1	6.1~6.4
-	154.9	43.6	12.3	5.6~5.9
-	143.9	40.5	11.4	5.1~5.4
4	132.8	37.3	10.5	4.6~4.9
-	121.7	34.2	9.6	4.1~4.4
-	110.7	31.1	8.8	3.6~3.9
-	99.6	28.0	7.9	3.1~3.4
3	88.5	24.9	7.0	2.6~2.9
-	77.5	21.8	6.1	2.1~2.4
2	66.4	18.7	5.3	1.6~1.9
-	55.3	15.6	4.4	1.1~1.4
1	44.3	12.4	3.5	0.6~0.9
0	33.2	9.3	2.6	0.1~0.4

Consult local ITOH DENKI representative in case you use Power Moller with nominal speed not in the above table.

## 5-2. Direction Setting

Reverse direction by external DIR signal can be permitted even while motor is running. Power Moller turning direction can be set or changed either internally by integral DIP switch or externally by optional switch.

### Setting for Turning Direction

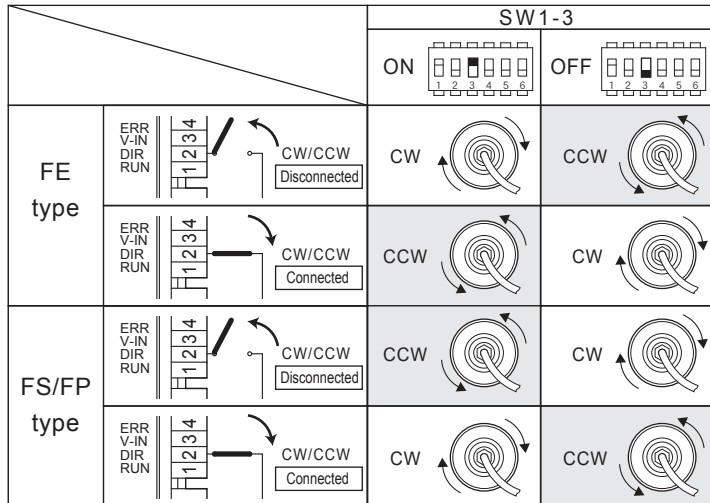

※Turning direction viewed from the Power Moller's power cable side.

※0V should be common to power voltage.

※7.3mA current is drawn at CN2-2.

### Reverse motor direction by external DIR signal. (CN2-2)

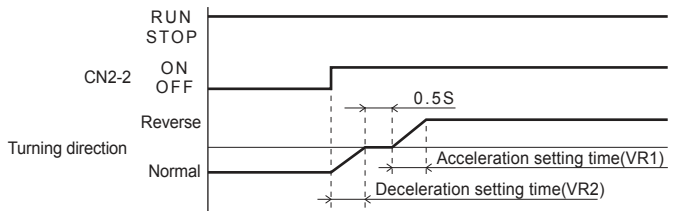

※Reverse direction by DIP switch is prohibited while motor is running. Motor must be stopped first, and then reverse a direction by DIP switch.

## 5-3. Acceleration and Deceleration

- Integral potentiometer VR1 allows the acceleration adjustment from 0 to 2.5seconds.
- Integral potentiometer VR2 allows the deceleration adjustment from 0 to 2.5seconds.

• The adjustable range of time is on the control basis, thus may differs on actual transfer speed.

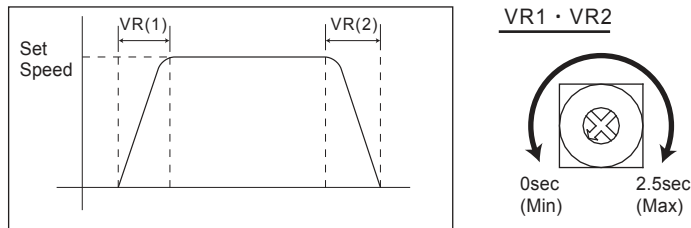

## 6. Error Signal Output

Error signal is discharged from CN2-4.

• Discharged the error signal discharged when power is injected to the driver card (for 0.5sec) and when power to the driver card is shut off (for 2 seconds)

- SW1-4 allows the selection of the error signal discharge timing: discharge on normal status or discharge when error arise. Error signal is PNP open collector in case of CBM-105FP.

※See section 8 for error status, reset and history.

SW1-6 ON	SW1-6 OFF
PNP open collector output	NPN open collector
SW1-4 OFF	SW1-4 ON
Error signal discharges in normal status	Error signal discharges when error arises
Open on normal ( Transistor on PCB is ON when error arises )	Open on error ( Transistor on PCB is OFF when error arises )

※Protective resistor should be mounted to suppress the output to be 25mA or less, otherwise the driver card's integral transistor may e damaged.

※100Ω protective resistor is built-in the driver card output section for error output.

## 7. Motor Pulse Signal Output

- Power Moller's motor pulse signal is discharged from CN2-5.
- 2pulses/motor rotation, NPN open collector output.

Speed deviation : ±3%

Internal speed variation	Frequency (Hz)	Motor speed (r/min)	Analog voltage input (V)
9	166	4969	9.6~9.9
8	152	4556	9.1~9.4
-	145	4349	8.6~8.9
7	138	4141	8.1~8.4
-	131	3934	7.6~7.9
6	124	3727	7.1~7.4
5	110	3313	6.6~6.9
-	104	3106	6.1~6.4
-	97	2899	5.6~5.9
-	90	2692	5.1~5.4
4	83	2485	4.6~4.9
-	76	2278	4.1~4.4
-	69	2071	3.6~3.9
-	62	1864	3.1~3.4
3	55	1657	2.6~2.9
-	48	1450	2.1~2.4
2	41	1242	1.6~1.9
-	35	1035	1.1~1.4
1	28	828	0.6~0.9
0	21	621	0.1~0.4

※Protective resistor should be mounted to suppress the output to be 25mA or less, otherwise the driver card's integral transistor may e damaged.

※100Ω protective resistor is built-in the driver card output section for motor pulse output.

## 8. Error status, Reset and History

- When error arises, the error can be identified either by LED1(Green) and LED2(Red) or by the error signal discharged from CN2-4.
  - To reset the error status, first remove the cause of error, and then switch the direction signal at CN2-2.
  - To restart to Power Moller, first remove the cause of error, and then re-inject RUN signal at CN2-1.
- ※ Reset the error by CN2-1(Run signal), the Power Moller start running immediately.  
 ※ In case power is 8.5V or less, the driver card may not work properly.

### LED indication

Illuminates	Blinks at 1Hz	Blinks at 6Hz	Blink twice at 6Hz ↓ Off for 1.5sec	Off

LED1 (Green)	LED2 (Red)	CN2-4 (Error signal)	MDR	Symptom/ Causes	Reset the error signal	Restart the Power Moller																
		SW1-4 ON	SW1-4 OFF	n.a.	Normal operation	n.a.																
		Open	Open	STOP	No power	Supply 24VDC power See section 5																
		Discharge	Open	STOP	PCB damaged	Shut off the power then replace the driver card See section 5																
		Discharge	Open	STOP	Thermister reacted (Thermister error)	<table border="1"> <tr> <td>Automatic recovery setting</td> <td>Power Moller restart immediately 1 minute after Thermister recovery from cooling off.</td> </tr> <tr> <td>Automatic recovery setting</td> <td>Power Moller restarts by injecting RUN signal followed by STOP signal to CN2-1 to reset the error signal then inject RUN signal to CN2-1 to restart, 1minute after Thermister recovery.</td> </tr> <tr> <td>Automatic recovery setting</td> <td>After Thermister recovery, inject signal ON-OFF-ON or OFF-ON-OFF order to CN2-2</td> </tr> <tr> <td>Automatic recovery setting</td> <td>Inject signal RUN-STOP-RUN order to CN2-1</td> </tr> <tr> <td>Automatic recovery setting</td> <td>Restarts automatically in a minute.</td> </tr> <tr> <td>Manual recovery setting</td> <td>Power Moller restarts by injecting RUN signal followed by STOP signal to CN2-1 to reset the error signal then inject RUN signal to CN2-1 to restart, 1minute after Thermister recovery.</td> </tr> <tr> <td>Manual recovery setting</td> <td>After Thermister recovery, inject signal ON-OFF-ON or OFF-ON-OFF order to CN2-2</td> </tr> <tr> <td>Manual recovery setting</td> <td>Inject signal RUN-STOP-RUN order to CN2-1</td> </tr> </table>	Automatic recovery setting	Power Moller restart immediately 1 minute after Thermister recovery from cooling off.	Automatic recovery setting	Power Moller restarts by injecting RUN signal followed by STOP signal to CN2-1 to reset the error signal then inject RUN signal to CN2-1 to restart, 1minute after Thermister recovery.	Automatic recovery setting	After Thermister recovery, inject signal ON-OFF-ON or OFF-ON-OFF order to CN2-2	Automatic recovery setting	Inject signal RUN-STOP-RUN order to CN2-1	Automatic recovery setting	Restarts automatically in a minute.	Manual recovery setting	Power Moller restarts by injecting RUN signal followed by STOP signal to CN2-1 to reset the error signal then inject RUN signal to CN2-1 to restart, 1minute after Thermister recovery.	Manual recovery setting	After Thermister recovery, inject signal ON-OFF-ON or OFF-ON-OFF order to CN2-2	Manual recovery setting	Inject signal RUN-STOP-RUN order to CN2-1
Automatic recovery setting	Power Moller restart immediately 1 minute after Thermister recovery from cooling off.																					
Automatic recovery setting	Power Moller restarts by injecting RUN signal followed by STOP signal to CN2-1 to reset the error signal then inject RUN signal to CN2-1 to restart, 1minute after Thermister recovery.																					
Automatic recovery setting	After Thermister recovery, inject signal ON-OFF-ON or OFF-ON-OFF order to CN2-2																					
Automatic recovery setting	Inject signal RUN-STOP-RUN order to CN2-1																					
Automatic recovery setting	Restarts automatically in a minute.																					
Manual recovery setting	Power Moller restarts by injecting RUN signal followed by STOP signal to CN2-1 to reset the error signal then inject RUN signal to CN2-1 to restart, 1minute after Thermister recovery.																					
Manual recovery setting	After Thermister recovery, inject signal ON-OFF-ON or OFF-ON-OFF order to CN2-2																					
Manual recovery setting	Inject signal RUN-STOP-RUN order to CN2-1																					



	Discharge	Open	STOP	MDR connector unplugged	Shut off the power off and re-plug connector properly.	See section 5
	Discharge	Open	STOP	Motor stall for 4 seconds	Inject signal RUN-STOP-RUN order to CN2-1 to reset the error and restart.	Inject signal RUN-STOP-RUN order to CN2-1
	Discharge	Open	STOP	Supply voltage less than 18VDC. (Under voltage error)	Automatic recovery setting	Restart immediately
					Manual recovery setting	Restart immediately
	Discharge	Open	STOP	Supply voltage more than 40VDC for 2sec or 60VDC for 0.1sec into the Power Moller. (Back EFM error)	Automatic recovery setting	Restart immediately
					Manual recovery setting	Restart immediately

Error can also be reset by shutting off the power for 2second or over.

※1 High voltage may be generated by turning the Power Moller over speed setting.

## 9. Servo Lock Brake

### Servo Lock Brake torque and current

Max brake torque	Max current
2.0N·m ※	1 (A)

※ PM486FE-60 type

### Servo Lock Brake...

- Hold Power Moller stop position when the Servo Lock Brake function is working.
- Move back to original stopped position when Power Moller force to be moved by external force.
- This feature is useful for conveyor where Power Moller is turned by external force. (Decline, Incline conveyor...etc)

## 10. Troubleshooting

※ Follow the procedures below without removing plastic cover or modifying the driver card, in case any problem happened.

Symptom 1; Power Moller does not run.	
Power	<ul style="list-style-type: none"> <li>• Check if only LED1 (Green) illuminates.</li> <li>• Check if 24VDC stable voltage is adequately supplied from the power supply.</li> <li>• Check if the wiring to CN1 connector is made correctly.</li> <li>• Check if 24VDC cable is adequately wired to the CN1 connector.</li> </ul>
RUN signal	<ul style="list-style-type: none"> <li>• Check if RUN signal is injected to CN2-1.</li> <li>• Check if signal is injected to CN2-1 is proper voltage. 0V for NPN setting, 24VDC for PNP setting.</li> <li>• Check if the wiring is adequately made to CN2-1 connector.</li> <li>• Check if the 0V injected to CN2-1 is common to 0V injected to CN1-2.</li> </ul>
Error	<ul style="list-style-type: none"> <li>• Check if LED2 is illuminating or blinking. If this is the case, see section 8 and remove the cause of error.</li> </ul>
Power Moller	<ul style="list-style-type: none"> <li>• Check if the Power Moller is adequately installed and its shaft are adequately fixed with the supplied mounting brackets or accessories.</li> <li>• Check if the Power Moller end housing is NOT contacting conveyor frame.</li> <li>• Check if the Power Moller's connector is properly inserted to the driver card.</li> <li>• Check if the belt tension is not too strong.</li> <li>• Check if the number of slaved idler rollers are adequate.</li> </ul>

Symptom 2; Speed variation is not achieved, or speed is slower than expected.	
Power Moller	<ul style="list-style-type: none"> <li>• Check if the nominal speed of the Power Moller to se if the right model is used to achieve the speed variation or to reach expected speed.</li> </ul>
SW 1 -2 setting	<ul style="list-style-type: none"> <li>• Check if the SW1-2 is set properly: ON for external speed variation and OFF for internal speed variation.</li> </ul>
Power	<ul style="list-style-type: none"> <li>• In case of external speed variation, check if the 0V is common to the 0V input to CN1-2.</li> <li>• Check if the stable 24VDC is supplied.</li> </ul>
CN2-3	<ul style="list-style-type: none"> <li>• Check if the wiring is adequately mode to CN2-3 connector.</li> <li>• Check if the analog voltage input is made between 0 and 10V</li> </ul>

Symptom 3; Reversing is not achieved.	
CW/CCW	<ul style="list-style-type: none"> <li>• Check if 0V is injected to CN2-2, and it is common to the 0V input to Cn1-2.</li> <li>• Check if the wiring is adequately made to CN2-1.</li> </ul>
SW 1 -3	<ul style="list-style-type: none"> <li>• Check if DIP-SW1-3 is not changed during the Power Moller running. The Power Moller can not be reversed by DIP SW1-3 during the Power Moller is running. First stop the Power Moller and then change DIP SW1-3, or use CN2-2 for reversing direction.</li> </ul>

Symptom 4; Error Signal Not Discharged.	
SW 1 -4	<ul style="list-style-type: none"> <li>• Check if the setting is made properly for discharge on normal or discharge when error arises.</li> </ul>
Voltage	<ul style="list-style-type: none"> <li>• Check if the external voltage is 24VDC or less and its 0V is common to the 0V input to CN1-2.</li> <li>• Check if the load(resistor) larger than 1kΩ is mounted.</li> </ul>
CN2-4	<ul style="list-style-type: none"> <li>• Check if the wiring is adequately done to CN2-4. (Wired for NPN or PNP)</li> </ul>

Symptom 5; Error signal is often discharged.	
LED 2(Red)	<ul style="list-style-type: none"> <li>• Check if LED 2 (Red) is blinking. If this is the case, thermal, lock, low voltage or Back EFM error is arises. See section 8</li> <li>• Check if power supply is enough capacity. See section 2</li> </ul>
Environment	<ul style="list-style-type: none"> <li>• Check if the product is used in the ambient temperature range between 0 and 40°C.</li> <li>• Check if the driver card back plate is affixed to the metallic plate face for better heat dissipation.</li> <li>• Check if the Power Moller is stalled in the conveyor line.</li> </ul>
Power Moller	<ul style="list-style-type: none"> <li>• Check if the Power Moller end housing is contacting the conveyor frame.</li> <li>• Check if the Power Moller's connector is properly inserted to the driver card.</li> <li>• Check if the Roller cable is disconnected, or about to disconnect.</li> </ul>

## 11. Dimensions

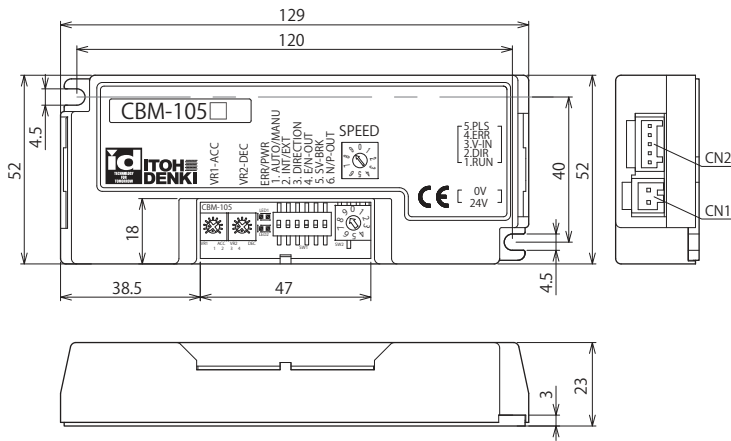

## 12. Specification

Power voltage	24VDC±10%	
Rated voltage	24VDC	
Static current	0.03A	
Peak current	20A 1msec or less	
Starting current	4.0A	
Motor starts running from RUN signal	≤15msec	
Error signal discharge	NPN/PNP transistor open collector (Should be set to 25mA to less max output current)	
LED	Power (Green) Error (Red)	
Protection	Integral 7A fuse (On +24VDC line) Diode against miss-wiring	
Thermister	95°C on PCB or 105°C in motor	
Type of brake	※1 Dynamic brake Servo brake	
Connector (Driver side)	Power	WAGO 734-162 (Max:10A)
	Control	WAGO 733-365 (Max:4A)
Connector (Wiring side)	Power	WAGO 734-102 (Max:10A)
	Control	WAGO 733-105 (Max:4A)
Environment Ambient	temperature	0°C~40°C
	Relative humidity	≤90%RH (No condensation)
	Atmosphere	No corrosive gas
	Vibration	≤0.5G

※1 No holding effect.

Contacts;



**Headquarters; Itoh Denki Co.,Ltd**

Phone: +08 (0)790 47 1225 Fax: +08 (0)790 47 1325 [www.itohdenki.co.jp](http://www.itohdenki.co.jp)

**Europe, Middle East, Africa: Itoh Denki Europe SAS**

Phone: +33 (0)4 50 03 09 99 Fax: +33 (0)4 50 03 07 60 [www.itoh-denki.com](http://www.itoh-denki.com)

**North & South America: Itoh Denki USA,INC**

Phone: +1 570 820 8811 Fax: +1 570 820 8838 [www.itohdenki.com](http://www.itohdenki.com)

**Asia/Oceania: Itoh Denki Asia Limited**

Phone: +852 2427 2576 Fax: +852 2427 2203

**China: Itoh Denki Shanghai Company Limited**

Phone: +86 21 6341 0181 Fax: +86 21 6341 0180 [www.itohdenki.cn](http://www.itohdenki.cn)

Specifications are subject to change without prior notice.

2-00K-2005