

LINESHAFT DRIVEN LIVE ROLLER CONVEYOR QUOTATION WORKSHEET

Company _____ Date _____
 Contact _____ Quote Due _____ Desired Delivery _____
 Phone No. _____ Contact Email _____ State _____
 Ultimation Sales Contact _____ Quote #: _____
 Quantity _____

Product Specs:
 Max:
 - Width (inches): _____ Length (inches): _____
 - Height (inches): _____ Weight (lbs): _____
 Min:
 - Width (inches): _____ Length (inches): _____
 - Height (inches): _____ Weight (lbs): _____
 Description: _____
 Max. Qty.: _____ Total Live Load: _____
 Temperature
 -Environment: _____
 -Product: _____

Roller Specs:
 1 3/8 in. dia. x 16 ga. Galv.
 1.9 in. dia. x 16 ga. Galv. Other: _____

Support Type:
 Quantity: _____
 Legs Ceiling Supports TOR _____ +/- _____

Other: _____

Conveyor Construction:
 Between Frame (BF) _____
 Roller C/C _____
 Straight Length: _____
 Curve - Degree: _____
 Inside Radius (I.R.): _____
 Bolt-Together
 Galvanize Painted Powder Coat
 Color/RAL: _____
 Welded
 Painted Powder Coat
 Color/RAL: _____

Drive Info:
 Drive Slave
 Underhung Side Mount
 Chain Timing Belt
 HP: _____

Plant Voltage:
 110V Single Phase 460V Three Phase
 220V Single Phase 208V Three Phase
 220V Three Phase 575V Three Phase
 Speed:
 FPM: _____ Fixed Variable (10:1 ratio)
 AC Controller DC Controller

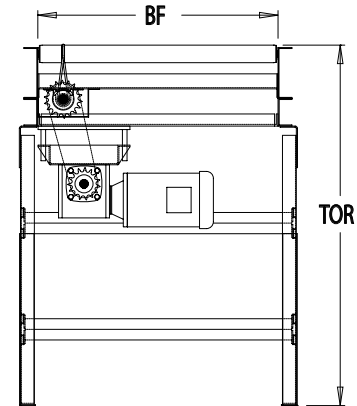

Underhung Drive with Leg Supports

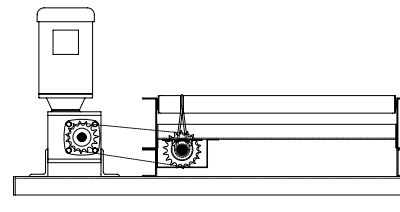

Side Mount Drive

Approval Drawing Required: Yes No