

## PRORUNNER MK10-VERTICAL CONVEYOR



Up to -22 F

Key Components for material handling:

- Vertical Sorting
- Palletising Modules
- Sorting & Buffering
- Pallet Stackers
- Safety Fencing

## Advantages of the Prorunner MK10

- Minimum footprint
- Suitable for multilevel vertical sorting
- Robust and low maintenance
- Automated drop down protection included
- Right-angle arrangement also possible
- Pallets, racks etc. up to 4410 lb
- No more lubricating or tightening of chains
- Steel solid construction
- Low noise



Key Components for material handling:

- Vertical Conveyors
- Palletisers
- Vertical Sorters & Buffers
- Pallet Handling
- Safety Fencing

Specifications Prorunner MK10		Basic model	Optional up to
Min. In / Outfeed	inch.	15.75	15.75
Max. In / Outfeed	inch.	115	981
Capacity	p/hour	60	Checked per RFQ
Product	LxW inch.	48 x 43	65 x 55
Weight	lb.	4410	4410



49 ft

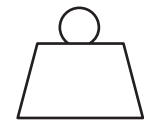
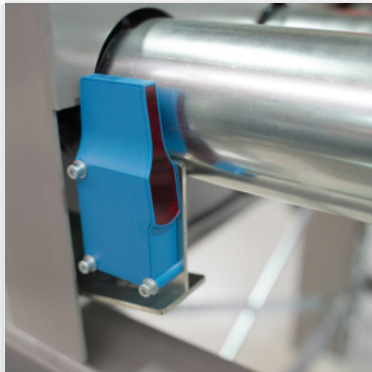
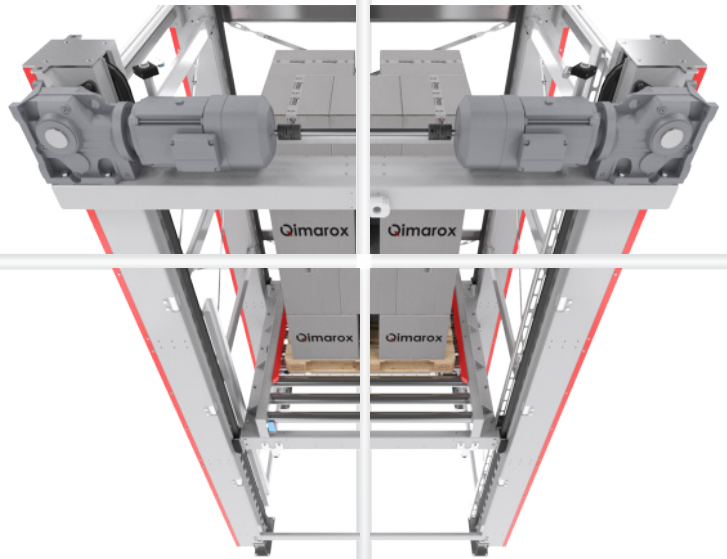

4410 lbs

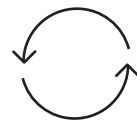

60 / h

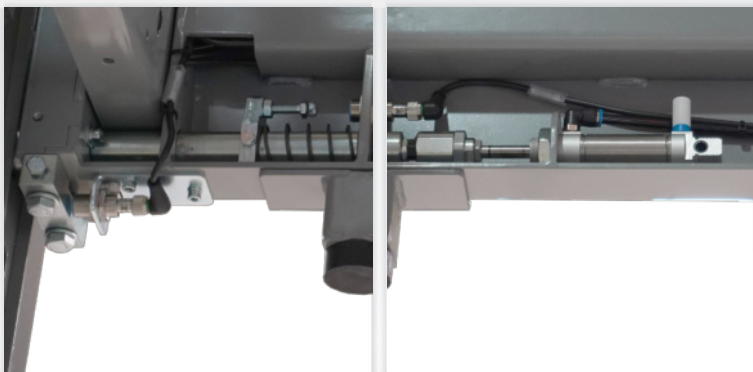
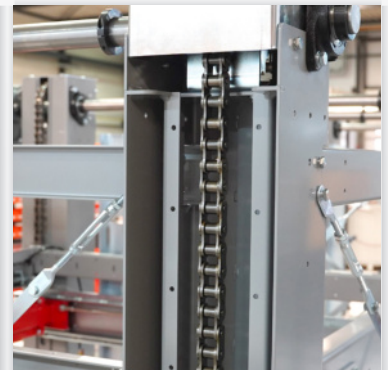

32 sq ft

Key Components for material handling:

- Vertical Conveyors
- Palletisers
- Vertical Sorters & Buffers
- Pallet Handling
- Safety Fencing

Customer: \_\_\_\_\_

E-mail: \_\_\_\_\_

Product:  Empty  Loaded

Product sizes: ..... x ..... x ..... inch.

Capacity: min. ....p/hour. max. ....p/hour.

Product weight: min. ....Lb. max. ....Lb.

Product orientation infeed:  SSL  LSL

Product orientation outfeed:  SSL  LSL

Product infeed height: .....inch.

Product outfeed height: .....inch.

Conveyor:  Yes  No

Type of conveyor:  Roller conveyor  Chain conveyor

Sensors included:  Yes  No

Safety fencing included:  Yes  No

Safety fencing door included:  Yes  No

Operational: ..... / ..... | ..... / .....  
Hour / Day Days / Week

Lay-out:  Send to info@ultimation.net

Environment conditions: \_\_\_\_\_

Remarks: \_\_\_\_\_

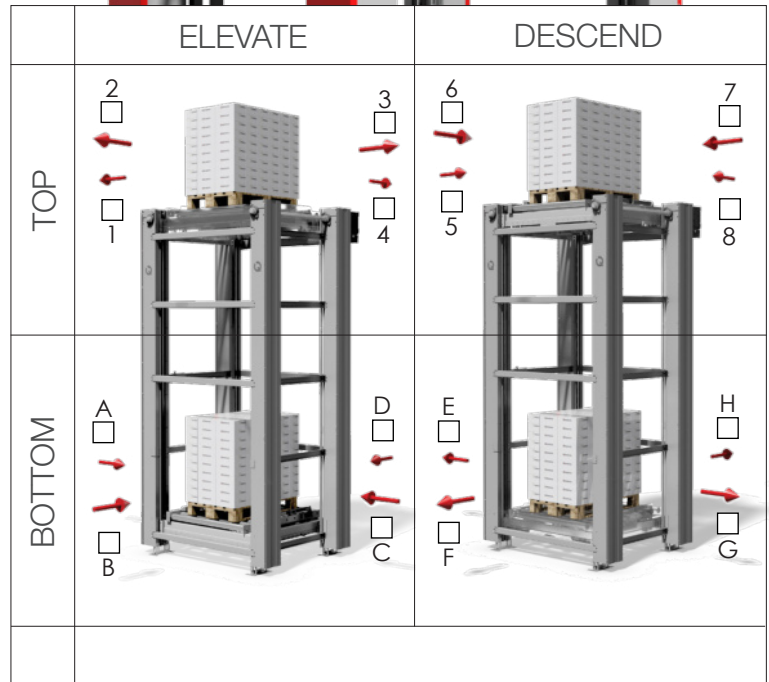

Disclaimer: This document is for informational en promotional purposes only.  
All orders are subject to the Qimarox terms and conditions and Qimarox's written confirmation. Copyright © 2022 Qimarox