

PRORUNNER MK9-VERTICAL CONVEYOR

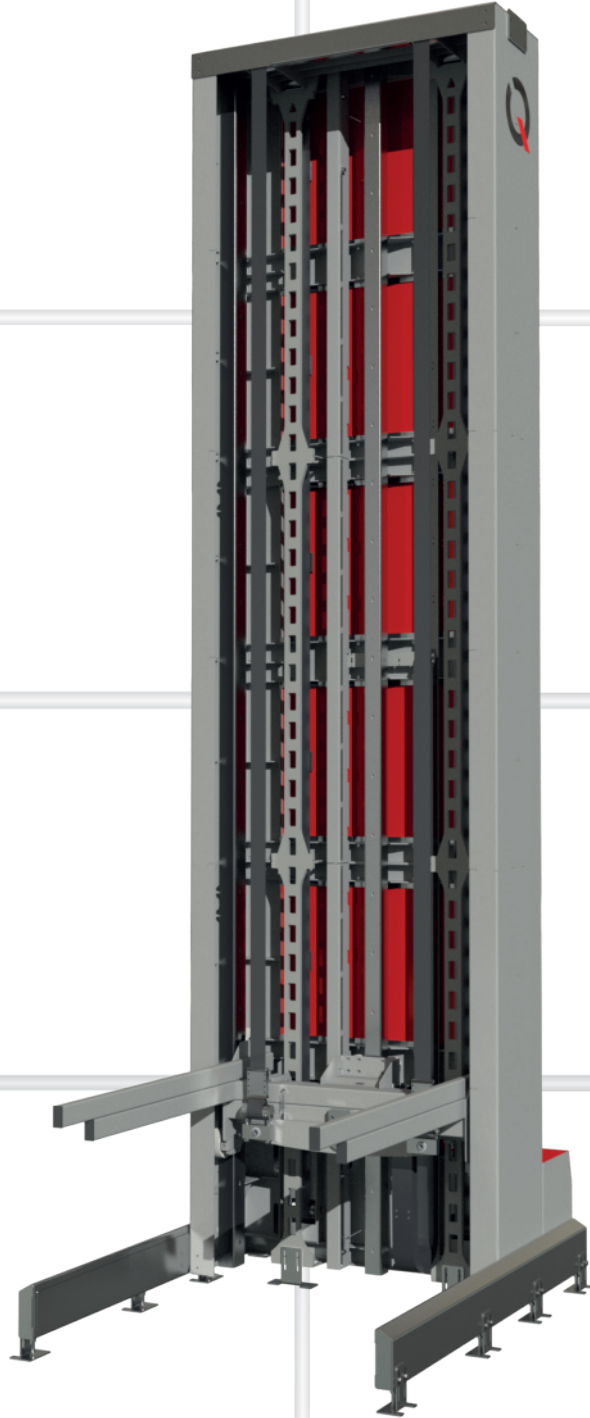

Key Components for material handling:

- Vertical Sorting
- Palletising Modules
- Sorting & Buffering
- Pallet Stackers
- Safety Fencing

Advantages of the Prorunner MK9

- Minimum footprint
- Suitable for multilevel vertical sorting
- Robust and low maintenance
- Drop down protection included
- No lubrication or chain tensioning required
- Right-angle arrangement also possible
- Pallets, racks etc. up to 2,760 Lb.
- Solid steel construction
- Drive motor at floor level
- Low noise



Key Components for material handling:

- Vertical Conveyors
- Palletisers
- Vertical Sorters & Buffers
- Pallet Handling
- Safety Fencing

Specifications Prorunner MK9		Basic model	Optional up to
Min. In / Outfeed	inch.	20	20
Max. In / Outfeed	inch.	105	420
Capacity	p/hour	60	Checked per RFQ
Product	LxW inch.	48 x 31	51 x 49
Weight	lb.	2,200	2,760



33 feet

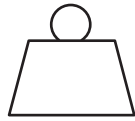
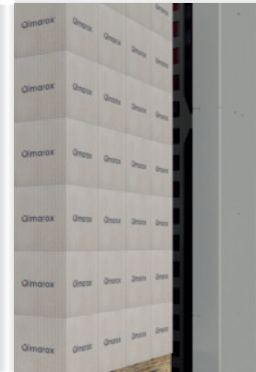

2,760 Lb

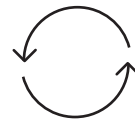

60 / h

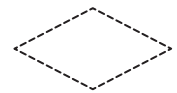

32 sq ft

Key Components for material handling:

- Vertical Conveyors
- Palletisers
- Vertical Sorters & Buffers
- Pallet Handling
- Safety Fencing

Customer: _____

E-mail: _____

Product: _____

Product sizes: _____ x _____ x _____ inch.

Capacity: min. _____ p/hour. max. _____ p/hour.

Product weight: min. _____ Lb. max. _____ Lb.

Product orientation infeed _____

Product orientation outfeed: _____

Product infeed height: _____ inch.

Product outfeed height: _____ inch.

Conveyor included: Yes No

Type of conveyor: Roller Chain

Sensors included: Yes No

Safety fencing: Yes No

Safety fencing door: Yes No

Operational: _____ / _____
Hour / Day Days / Week

Lay-out: Send to info@ultimation.net

Environment conditions: _____

Remarks: _____

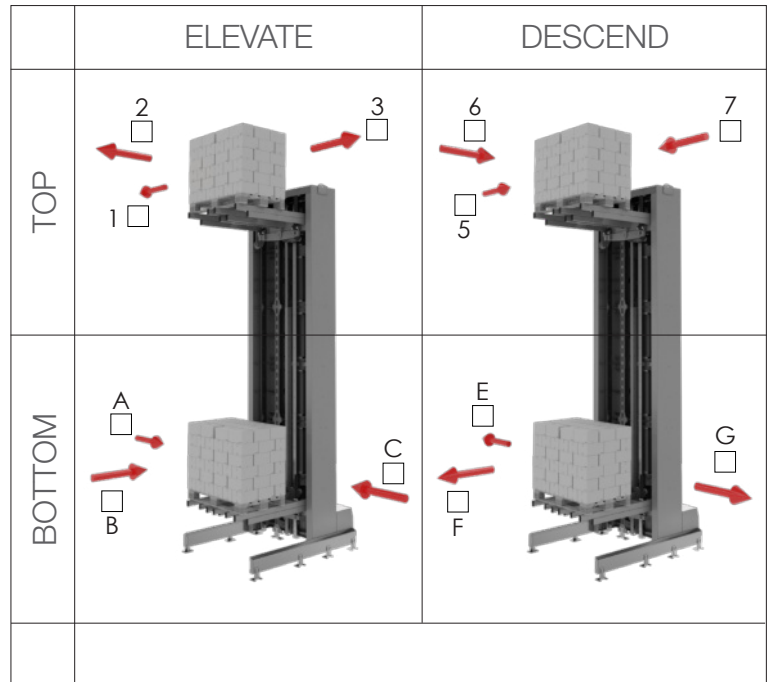
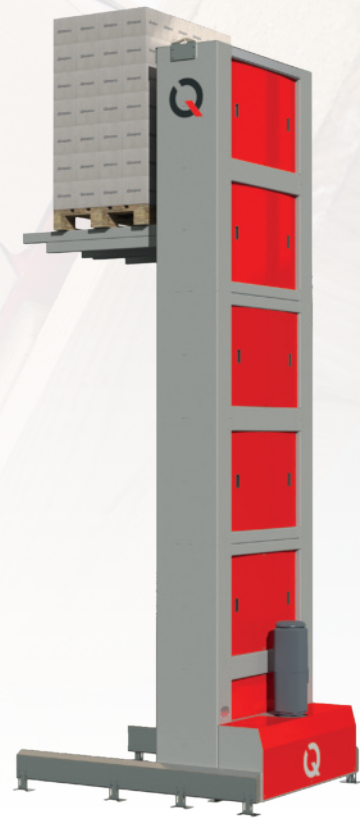

Disclaimer: This document is for informational en promotional purposes only.
All orders are subject to the Qimarox terms and conditions and Qimarox's written confirmation. Copyright © 2022 Qimarox