

POWERED FLEX CONVEYOR WORKSHEET

Company _____ Date _____
 Contact _____ Quote Due _____ Desired Delivery _____
 Phone No. _____ Contact Email _____ State _____
 Sales Contact _____ Quote #: _____
 Quantity _____

Product Specs:

Max: _____
 Width (inches): _____ Length (inches): _____
 Height (inches): _____ Weight (lbs): _____
 Min:
 Width (inches): _____ Length (inches): _____
 Height (inches): _____ Weight (lbs): _____
 Description: _____
 Max. Qty.: _____ Total Live Load: _____
 Capacity Limitations (must meet all three)
 15 lbs/roller, 50 lbs/ft, 100 lbs/zone

Conveyor Construction:

Between Frame (BF): 18" 24" 30" 36"
 Expanded Roller Centers: 3" 4" 5"
 Expanded Length: 25' 40' 50' 60' 80'
 *Note: custom lengths are available, consult factory
 Casters: 5" 6" 8"

Height:

30" TOR, +/- 4" adjustment
 34" TOR, +/- 4" adjustment

Speed:

Fixed _____ FPM
 Variable _____ to _____ FPM

Options:

Flexible Side Guides Interface Kit
 Reversing Stop Stopping Photo-eye

Approval Drawing Required: Yes No

Roller Specs:

1.4" roller diameter, 18 ga
 1.9" roller diameter, 16 ga.

Application Type:

Transportation Loading
 Accumulation Unloading
 Both

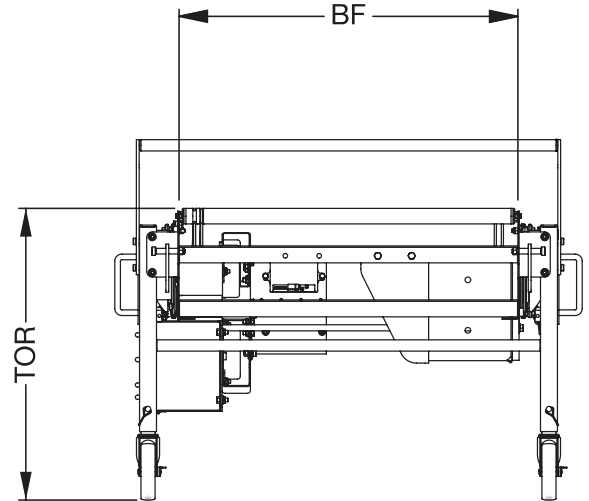

Impact Cart:

Integrated Powered
 Stand Alone Gravity
 1.9" roller diameter, 16 ga.
 2.6" roller diameter, 10 ga.

Notes: _____

