

ULTIMATION»»

AN MCE»» COMPANY

POWERED FLEX CONVEYOR INSTALLATION, OPERATION & MAINTENANCE MANUAL

PLEASE REVIEW MANUAL BEFORE OPERATING EQUIPMENT



TABLE OF CONTENTS

General Overview.....	3
Product Specifications.....	4
Warnings and Safety Information.....	6
Inspecting the Equipment.....	8
Inspection Checklist.....	9
Installation Quick Start: 1 Powered Flex Conveyor	10
Connecting Powered Flex Conveyors: 2 or 3 Powered Flex Conveyors	11
Communication Connection	17
Operating Instructions	19
General Preventative Maintenance.....	21
General Troubleshooting	22
Controller Technical Information.....	23
Troubleshooting: Controller	24
Warranty Statement.....	26
Return Authorization Procedures.....	27
Parts Reference Chart & Drawings.....	28

GENERAL OVERVIEW

Ultimation Industries LLC Powered Flex Conveyor is a flexible, expandable, portable, powered roller conveyor that will stretch or bend to fit your available space and is ideal for truck loading and unloading areas, distribution centers or portable assembly lines.



Accumulation Style: Each zone contains a sensor array, motor and smart conveyor control logic. Zones run on demand only when the downstream zone is unoccupied. Packages accumulate at the end of a conveyor or in the zones prior to a full zone.

Transportation Style: Conveyor is always on, transporting packages continuously at a constant speed.

Features:

- Variety of sizes to meet a wide range of applications

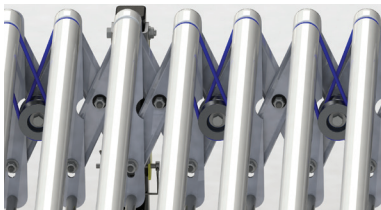

Figure 1

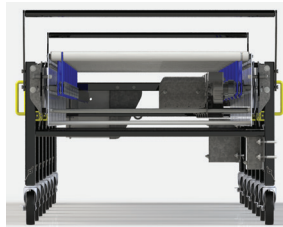

Figure 2

- 110 VAC input power
- Heavy-duty, sealed, quick-connect power cabling
- Rollers driven by high-tension, urethane O-ring belts
- Roller precision bearings
- Supports at 30" top of roller
- Locking, swivel casters with brake
- Pin-adjustable height plus or minus 4" on 1/2" increments
- Powder coated frame and supports

- Aluminum side flex bars
- Start/Stop button at each end
- Forward/Reverse switch on base end
- Entrance zone interface box includes dry contact relays for control of entrance zone driver card
- Exit zone interface box has speed control potentiometer along with dry contact relays for control of exit zone driver card

Accumulation Features:

- Motor driver cards contain internal accumulation logic
- Multiple release modes
- Run-On-Demand power savings
- Photo eye sensor array across full width in each zone
- Quick-connect RJ-12 communication cables
- Optional reverse mode is transportation only with package stop photoeye available

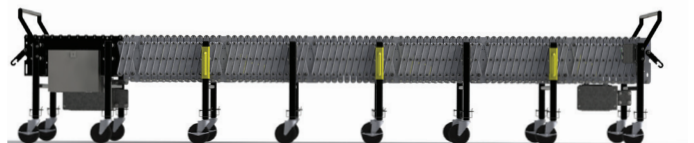

Figure 3

PRODUCT SPECIFICATIONS

GENERAL

Conveyor Bed Width (BF)	18", 24", 30", 36"
Conveyor Length	25', 40', 50', 60', 80'
Compressed Length	Varies; determined by the diameter of the roller and the center to center distance of the rollers see REFERENCE CHART for more details
Conveyor Height	26" to 34" top of roller; adjustable with locking pin
Speed	60 to 150 feet per minute (FPM)
Capacity	1.4" diameter rollers: 50 pounds per linear foot (PLF) and 100 pounds per zone. 1.9" diameter rollers: 15 pounds per roller, 100 pounds per linear foot* (PLF) and 100 pounds per zone. (*=decreased life of drive bands)
Noise Level	70dB @ conveyor bed c/l (30" TOR); 60dB @ ear level, approximately 5' 6" height from ground level

POWER REQUIREMENTS

Expanded Length (ft.)	Amps	Number of Zones
25	9.9	8
40	9.9	13
50	15.1	16
60	15.1	19
80	19.8	26

DRIVE MOTOR

Voltage	24 VDC
Torque	15" LBF, continuous
AMPS	4 amps
WATTS	100 w

MATERIALS

Casters	5", 6", or 8"; swivel, locking and non-locking, alternating
Side Links	Aluminum
Leg Supports	Welded H-Style 1 1/2" square tube legs
Belts	3/16" diameter Cyclothane-B
Photo eyes	Sensor array across the full width of each zone

ROLLERS

Roller Diameters	1.4" or 1.9"
Expanded Roller Distance	3", 4" or 5" and varies by roller diameter, see REFERENCE CHART for more details

REFERENCE CHART

Roller Diameter (in.)	Expanded		Rollers Per Zone	Compression Ratio
	Roller CC	Zone Length		
1.4	3"	38"	13	1.8: 1
	4"	38"	10	2.2: 1
	5"	42"	9	2.6: 1
1.9	4"	38.5"	10	1.6:1
	5"	42.5"	9	2:1

AVAILABLE MODE OF OPERATION

Transportation Style	Conveyor is always on, transporting packages continuously at a constant speed
Accumulation Style	Each zone contains a sensor array, motor and smart conveyor control logic. Zones run on demand only when the downstream zone is unoccupied. Packages accumulate at the end of a conveyor or in the zones prior to a full zone.

SHIPPING

Conveyor shipping weight per linear foot (PLF) for 1.4" roller size, 30" width

Roller centers (in.)	Weight (lbs.)
3	50
4	38
5	35

ACCESSORIES

Floor Guide	Move the Flex Conveyor in and out of storage with ease
Side Guides	Guides are 4" tall covering up to two zones of the conveyor made of heavy-duty UHMW polyethylene
Impact Cart	Inserted at infeed end of the conveyor, it is designed to handle package impact reducing the need for continual repairs to the conveyor
Transition	Available in Centering and Straight options and assist in moving packages from the feed line to the Flex Conveyor. The Centering option also aligns packages toward the center of the Flex Conveyor.
Power Assist	Safely and easily move the Flex Conveyor in position for operation or storage.

WARNINGS AND SAFETY INSTRUCTIONS

Failure to follow the instructions and cautions throughout this manual and warning labels on the conveyor, may result in injury to personnel or damage to the equipment.

Ultimation Industries Powered Flex Conveyor is motor-powered and this motor can be stopped by turning off the motor's electrical power. As with all powered machinery, the drive-related components can be dangerous so safety guards and other optional devices have been installed to prevent accidental contact with these parts along with warning labels to identify potential hazards.

Special attention must be paid to the following areas of this manual:



WARNING

Indicates a potentially hazardous situation which, if not avoided, could result in death or serious injury.

CAUTION

Indicates a situation which, if not avoided, could result in property damage.

NOTE

Indicates helpful hints and information

ENVIRONMENTAL STANDARDS

Ultimation Industries equipment is designed to be installed in a clean, dry environment. Exposure to extreme humidity, direct sunlight, blowing dirt or rain can permanently damage some components and equipment. Concrete curing agents are also known to attack and degrade the urethane conveyor components. Be sure that the concrete is properly cured at new sites before setting the conveyor on it and that proper ventilation is used to prevent curing agent fumes from impacting the conveyor. Equipment should be stored under cover to protect it from exposure to the weather and other adverse conditions from the dock door to the truck entrance. Failure to comply with these guidelines will void the warranty on any failed components that result from these environmental issues.

ANSI STANDARDS FOR CONVEYORS

It is essential for safe and efficient system operation that the safety information and guidelines presented here are properly understood and implemented. The American National Standard Institute (ANSI) booklet entitled Safety Standards for Conveyors and Related Equipment, for more information contact <https://webstore.ansi.org>.

With any piece of industrial equipment, conditions exist that might cause injury to workers. Because it is not possible to describe each potentially hazardous situation that might develop, workers must be alert at all times for unsafe conditions. To avoid injury, use maximum possible care and common sense and adhere to all safety standards.

Take special care while maintaining and inspecting electrical equipment and devices. All personnel working on or around the system should be aware of, and adhere to all CAUTION, DANGER and WARNING signs.

Labels or signs are posted to reduce the risk of injury to all personnel. Never assume that the signs and notices are applicable only to inexperienced personnel. Maintain signs in a legible condition. Contact a supervisor to post additional safety signs if necessary.

ANSI CONVEYOR SAFETY RULES

Below are the conveyor safety rules, as well as specific regulations and guidelines listed in this publication:

- DO NOT touch moving Conveyor parts.
- DO NOT walk, ride or climb on the Conveyor.
- DO NOT operate the Conveyor with chain guards or other protective guards removed.
- Keep jewelry, clothing, hair, etc., away from the Conveyor.
- Know the location and function of all start/stop devices and keep those devices free from obstruction.
- Clear all personnel from the equipment before starting the Conveyor.
- DO NOT attempt to clear product jams while the Conveyor is running.
- Allow only trained and authorized personnel to maintain or repair Conveyor equipment.
- DO NOT load the Conveyor beyond specified design limits.
- DO NOT attempt to make repairs to the Conveyor while it is running.
- DO NOT modify equipment without checking with the manufacturer.

- DO NOT operate or perform maintenance on equipment when taking any type of drug or sedative, when under the influence of alcohol or when over-fatigued.
- Report any unsafe condition to your supervisor or maintenance staff.

CEMA STANDARDS FOR CONVEYOR

The Conveyor Equipment Manufacturers Association (CEMA) provides safety information related to conveyor systems. To learn more about CEMA visit website, www.cemanet.org.

CEMA produces various Conveyor safety videos and posters, and it is recommended that the videos be made available for training and education purposes as part of a safe working environment around conveyor equipment. The videos introduce awareness of operations, personnel, maintenance technicians and safety hazard management commonly associated with the automated material-handling conveyor equipment.

The safety posters review important safety labels and are intended to be posted in public places as a day-to-day reinforcement of good safety practices. These posters can be downloaded from the CEMA website at: <http://www.cemanet.org/safety-label-posters>.

SAFETY INSTRUCTIONS



WARNING

- Move conveyor only by grasping the handles located on the sides or at each end of the conveyor.
- When expanding or compressing your conveyor, keep hands, clothing and other items clear of the sidebars.
- Do not exceed the conveyor load capacity, as it may result in possible operator injury or conveyor damage.
- Avoid wearing excessively loose clothing when working with moving equipment.
- Keep long hair pulled up to prevent it from becoming caught in moving parts.
- Broken or worn parts must be replaced immediately.
- Powered Flex Conveyors must only be serviced by properly trained and qualified technicians.
- Conveyor's power cord must be connected to a grounded receptacle that is protected by an overcurrent device rated at no more than 30 Amps, unless otherwise specified.
- Never service a conveyor with the power applied. Always disconnect power before servicing equipment and use the company's machine specific lockout/tag out procedures.
- Never operate conveyor with an electrical enclosure open or any guards removed.

INSPECTING THE EQUIPMENT



WARNING

Follow all proper safety precautions and plant installation procedures.

If you find any damage to the conveyor upon inspection or any loose wires, contact the factory **BEFORE** applying power to the conveyor.

- 1) Unpack the Powered Flex Conveyor and inspect for any possible damage that may have occurred during shipping. Pay particular attention to the wiring to ensure that no wires are pulled loose or damaged. If you find any physical or electrical damage to the conveyor upon inspection, contact the factory **BEFORE** applying power to the conveyor.
- 2) Inspect all electrical cables and connectors to ensure they did not loosen during transportation. If a connection or wire is loose, inspect for damage. If no damage is found, reconnect and contact the factory as needed.
- 3) Check end handles at each end of the conveyor for damage by lifting to unlatch and then re-latch into a secure position. If there is any binding or difficulty moving the handle from latch to unlatch and re-latch, the handle may be damaged, contact the factory.
- 4) Inspect the sidebars of the Conveyor for damage during shipping. If the sidebars are damaged, the Conveyor will not move or run properly and needs to be repaired prior to operation. Contact the factory for parts and further instruction.
- 5) Inspect the rollers to ensure the rollers were not damaged during shipping. If the rollers are bent, the conveyor will not move products or operate properly resulting in poor performance. The Conveyor rollers will need to be replaced. Contact the factory for parts and further instruction.
- 6) Inspect each leg to ensure that the height adjustment pins are securely in place. Missing pins will prevent the Conveyor from moving properly and will result in damage to the Conveyor. Missing pins should be located and replaced prior to movement and installation.



Figure 4: Height adjustment pin

- 7) Inspect the casters and legs to ensure no damage occurred during shipping. Check all welds and attachments to the Conveyor. If the casters are damaged, then the Conveyor will not move properly, which will result in damage to the Conveyor. The Conveyor will need to be repaired. Contact the factory for parts and further instruction.
- 8) Inspect the conveyor to ensure all yellow handles are secured in the proper location. The Conveyor will have a pair of yellow handles, one on each side of the Conveyor for each zone, to assist with safe positioning of the Conveyor. The exact number of handles will vary depending on the zone quantity and length of the Conveyor.

INSPECTION CHECKLIST

The checkboxes below ensure all items have been inspected for safety:

✓	Chart Reference	Description
	1	Yellow handles in place, not bent. Check each zone and each side of the conveyor.
	2	Side links are not bent
	3	Casters and legs secure, not bent, and no missing parts
	4	Handles are not bent. Handles unlatch and latch without binding
	5	Rollers are not bent
	6	Height adjustment pins in place on each leg
	7	Power cords, communication cables are secure, not tight and not loose



Figure 5: Full view, Powered Flex Conveyor

VOLTAGE AND AMPERAGE

Voltage and amperage requirements for the Powered Flex Conveyor are as follows:

Conveyor Length	40'	60'	80'
Amps	9.9	15.1	19.8
Power	110VAC	110VAC	110VAC

ACCUMULATION AND TRANSPORTATION MODE

The Powered Flex Conveyor is available in two modes to meet load and unload requirements: Accumulation and Transportation.

Accumulation

In Accumulation mode, each zone contains a sensor array, motor, and smart conveyor control logic. Zones run on demand only when the downstream zone is unoccupied. Packages accumulate at the end of a conveyor or in the zones prior to a full zone.

Transportation

In Transportation mode, the conveyor is always on, transporting packages continuously at a constant speed.

INSTALLATION QUICK START: 1 POWERED FLEX CONVEYOR

- 1) All STOP push-buttons should be depressed, START/STOP buttons are located at each end of the conveyor. Ensure the Disconnect switch located on the Power Panel is in the OFF position.
- 2) Make sure FWD/REV switch is set to FWD.
- 3) Roll the conveyor into position in accordance with the warnings. Move the conveyor by grasping the handles located on the sides or at each end of the conveyor. If applicable, use the connect hooks to attach the Powered Flex Conveyor to a rigid or other flexible conveyor.
- 4) Ensure the height of the conveyor is adjusted to height of the infeed and discharge conveyor lines, as well as other material-handling equipment, in order to prevent packages and products from dropping or binding on the Powered Flex Conveyor during movement.
- 5) Ensure the conveyor rollers are not making contact with any infeed conveying equipment and/or discharge conveying equipment or other material-handling equipment.



Figure 6: START/STOP buttons



Figure 7: Power Panel with Disconnect Switch

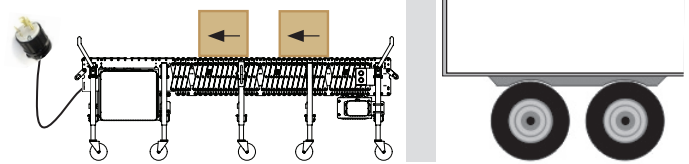

Figure 8: Powering a single Powered Flex Conveyor, unload in accumulation mode

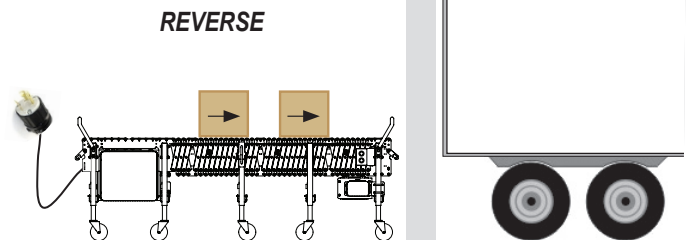

Figure 9: Powering a single Powered Flex Conveyor REVERSE, load in transportation mode



WARNING

Conveyor must be installed in accordance with all local, city, state and national code.

- 6) Each Powered Flex Conveyor requires a Grounded 110VAC/30 AMP L5-30R receptacle located close enough to the conveyor so as to not cause any strain on the power cable. Plug the unmarked power cord with the L5-30P male connector into a 110VAC/30 AMP Grounded L5-30R female receptacle. **For connecting more than 1 Powered Flex Conveyor, see CONNECTING POWERED FLEX CONVEYORS.**
- 7) To start the conveyor, locate the base end with the power supply enclosure and turn the disconnect switch on. Locate one of the ON/OFF switches for the conveyor and press the green ON button when ready to start the conveyor.
- 8) If necessary, the speed of the conveyor can be adjusted via the potentiometer on the DC Variable Speed Drive located at the base end of the conveyor.
- 9) The conveyor is now ready for its intended use and packages can now be placed on the conveyor.

NOTE

Rollers will begin to move as soon as the ON button is pressed. If step 2 was not followed, the rollers will turn on as soon as the disconnect is turned to ON

CONNECTING POWERED FLEX CONVEYORS: 2 OR 3 POWERED FLEX CONVEYORS

Up to (3) Powered Flex Conveyors can be connected together to extend the distance covered from the loading dock to other in process conveyors and/or equipment.

Each Powered Flex conveyor requires its own grounded 110VAC/30 AMP L5-30R receptacle power drop. Up to (3) Powered Flex conveyors or maximum of 120 feet conveyor can be connected together using the Red and Yellow marked, 10/3 SJOOW pass through cables. The standard model has pass through cables that are set up for unloading trucks in accumulation mode. Please consult the factory regarding pass through cable orientation required for loading trucks in accumulation mode.

- 1) All STOP push-buttons should be depressed. There is one START/STOP switch at each end of the conveyor. Ensure Disconnect switch is in the OFF position.
- 2) Make sure FWD/REV switch is set to FWD.
- 3) Roll the conveyor(s) into position in accordance with the warnings. Move the conveyor by grasping the handles located on the sides or at each end of the conveyor. If applicable, use the connect hooks to attach the Powered Flex Conveyor to a rigid or other flexible conveyor.
- 4) Ensure the height of the conveyor is adjusted to the height of the infeed and discharge lines, as well as other material-handling equipment, to prevent packages and products from dropping or binding on the Powered Flex Conveyor during movement.
- 5) Ensure the conveyor rollers are not making contact with any infeed conveying equipment and/or discharge conveying equipment or other material-handling equipment.

- 6) Each Powered Flex Conveyor requires a grounded 110VAC/30 AMP L5-30R receptacle located close enough to the conveyor so as to not cause any strain on the power cable.

Each Powered Flex Conveyor is equipped with the following:

Quantity	Description
(1)	Unmarked, 10/3 SJOOW 6-foot power cable with twist lock L5-30P plug at the conveyor discharge end
(1)	Red marked, 10/3 SJOOW pass through power cable with L5-30R receptacle flush with the conveyor Infeed end and a L5-30P plug and 6 feet extension at the discharge end
(1)	Yellow marked, 10/3 SJOOW pass through power cable with L5-30R receptacle flush with the conveyor Infeed end and a L5-30P plug and 6 feet extension at the discharge end
(1)	Blue marked, 10/3 SJOOW reverse pass through power cable with L5-30R receptacle flush with the conveyor Infeed end and a L5-30P plug and 6 feet extension at the infeed end



Figure 10: START/STOP buttons



Figure 11: L5-30P and L5-30R receptacle ends

WARNING

Conveyor must be installed in accordance with all local, city, state and national code.

CONNECTING CONVEYOR 2

Unload Accumulation Mode and Load Transportation Mode

(2) Powered Flex Conveyors can be connected together and run in either Accumulation Mode or Transportation Mode depending on the flow of packages.

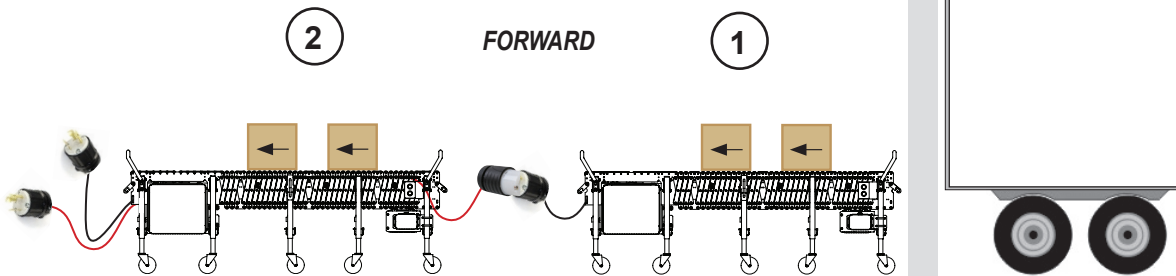

Figure 12: (2) Powered Flex Conveyors connected, unload accumulation mode

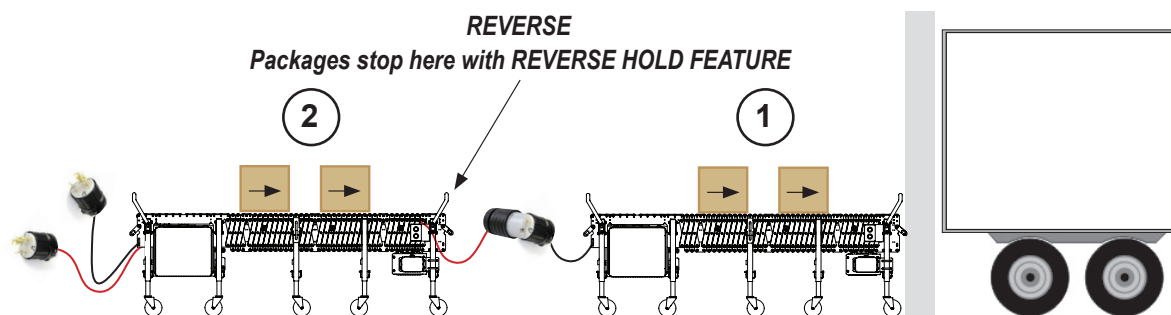

Figure 13: (2) Powered Flex Conveyors, REVERSE, load transportation mode

NOTE

Some conveyor models include a Reverse Hold feature which will result in packages stopping at the end of Conveyor 2.

- 1) Locate the unmarked power cable with L5-30P plug on conveyor 1 (the conveyor closest to the loading dock door) and plug it in to the Red marked, 10/3 SJOOW pass through power cable L5-30R receptacle flush with the conveyor 2 infeed end. Ensure Disconnect switch is in the OFF position.
- 2) Plug both the unmarked power cable L5-30P plug and the Red marked power cable L5-30P plug at the discharge end of conveyor 2 into individual L5-30R receptacles so that each has grounded power.
- 3) If connecting in Accumulation mode, ensure the yellow, 6-pin Turck cable is connected between the infeed end of conveyor 2 and the discharge end of conveyor 1 to allow communication.
- 4) To start the conveyor, locate the base end with power supply enclosure and turn the disconnect switch on. Locate one of the ON/OFF switches for the conveyor and press the green ON button when ready to start the conveyor.
- 5) If necessary, the speed of the conveyor can be adjusted via the potentiometer on the DC Variable Speed Drive located at the base end of the conveyor.
- 6) The conveyor is now ready for its intended use and packages can be placed on the conveyor.

NOTE

Rollers will begin to move as soon as the ON button is pressed. If step 2 was not followed, the rollers will turn on as soon as the disconnect is turned to ON

CONNECTING CONVEYOR 2

Load Accumulation Mode: Option For "F" Model Units

(2) Powered Flex Conveyors can be connected together and run in either Accumulation Mode or Transportation Mode depending on the flow of packages.

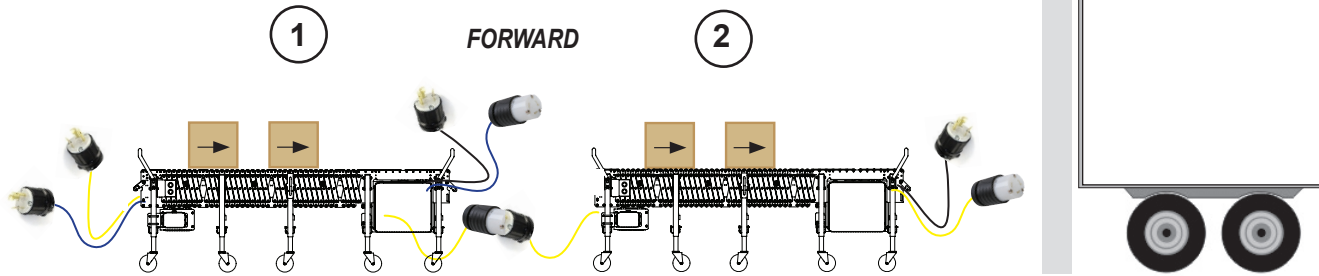

Figure 14: (2) Powered Flex Conveyors connected, load accumulation mode

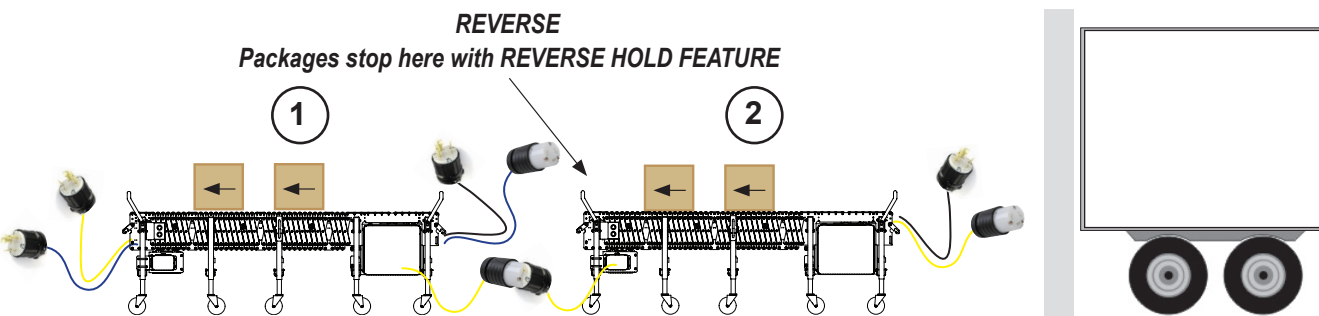

Figure 15: (2) Powered Flex conveyors connected, REVERSE, unload transportation mode

NOTE

Some conveyor models include a Reverse Hold feature which will result in packages stopping at the end of Conveyor 2.

- 1) Locate the unmarked power cable with L5-30P plug on conveyor 2 (the conveyor closest to the loading dock door) and plug it in to the Yellow marked, 10/3 SJOOW pass through power cable L5-30R receptacle flush with the conveyor 2 discharge end. Ensure Disconnect switch is in the OFF position.
- 2) Plug the Yellow marked cable with L5-30P plug on the infeed end of conveyor 2 into the Yellow marked, 10/3 SJOOW pass through power cable L5-30R receptacle flush with the discharge end of conveyor 1.
- 3) Locate the unmarked power cable with L5-30P plug on conveyor 1 (the conveyor farthest from the loading dock door) and plug it in to the Blue marked, 10/3 SJOOW pass through power cable L5-30R receptacle flush with the conveyor 1 discharge end.
- 4) Plug both the Yellow marked, 10/3 SJOOW pass through power cable and Blue marked, 10/3 SJOOW

pass through power cable L5-30 plugs at the infeed end of conveyor 1 into individual L5-30R receptacles so that each conveyor has power that is grounded.

- 5) Ensure the Yellow, 6-pin Turck cable is connected between the discharge end of conveyor 1 and the infeed end of conveyor 2 to allow communication.
- 6) To start the conveyor, locate the base end with power supply enclosure and turn the Disconnect switch to the ON position. Locate the ON/OFF switches for the conveyor. When ready to START, press the green ON button.
- 7) If necessary, the speed of the conveyor can be adjusted via the potentiometer on the DC Variable Speed Drive located at the base end of the conveyor.
- 8) The conveyor is now ready for its intended use and packages can be placed on the conveyor.

NOTE

Rollers will begin to move as soon as the ON button is pressed. If step 2 was not followed, the rollers will turn on as soon as the disconnect is turned to ON

CONNECTING CONVEYOR 3

Unload Accumulation Mode and Load Transportation Mode

(3) Powered Flex Conveyors can be connected together and run in either Accumulation Mode or Transportation Mode depending on the flow of packages.

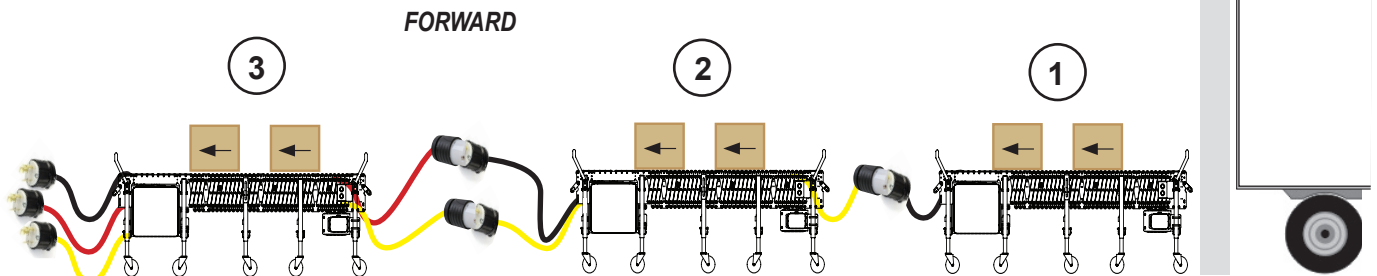

Figure 16: (3) Powered Flex Conveyors connected, unload accumulation mode

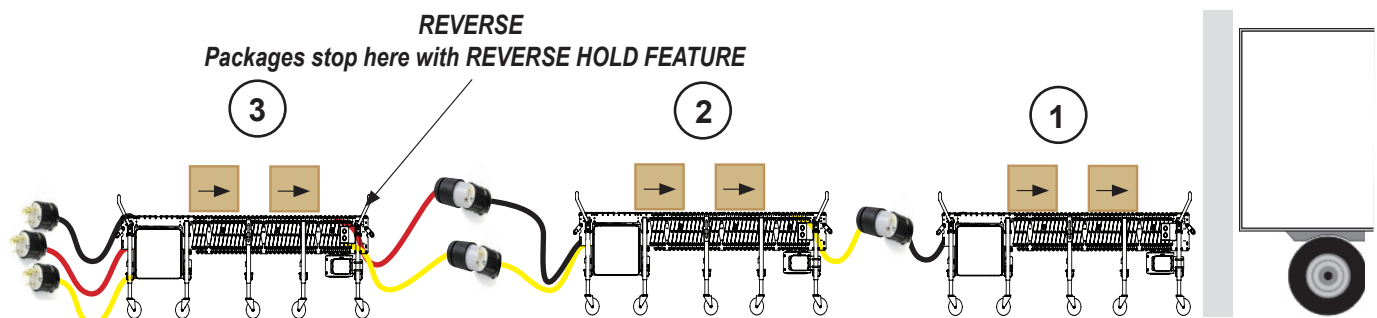

Figure 17: (3) Powered Flex Conveyors, REVERSE, load transportation mode

NOTE

Some conveyor models include a Reverse Hold feature which will result in packages stopping at the end of Conveyor 2.

- 1) Locate the unmarked power cable with the L5-30P plug on conveyor 1 (the conveyor closest to the loading dock door) and plug it in to the Yellow marked pass through the power cable L5-30R receptacle flush with the conveyor 2 infeed end. Ensure Disconnect switch is in the OFF position.
- 2) At the discharge end of conveyor 2 plug the Yellow marked pass through power cable L5-30P plug into the Yellow marked power cable L5-30R receptacle flush with conveyor 3 infeed end. Additionally, locate the unmarked power cable with the L5-30P plug on the conveyor 2 discharge end and plug in the L5-30P plug into the Red marked pass through power cable L5-30R receptacle at the discharge end of conveyor 3.
- 3) Plug all (3) L5-30P plug power cables at the discharge end of conveyor 3 into individual L5-30R receptacles so that each cable, unmarked, Yellow marked and Red marked power cables have grounded power.
- 4) If connecting Accumulation style Flex, ensure the yellow, 6-pin Turck cable is connected between the infeed end of conveyor 2 and the discharge end of conveyor 2, and between the infeed end of conveyor 2 and the discharge end of conveyor 1 to allow communication.
- 5) To start the conveyor, locate the base end with the power supply enclosure and turn the disconnect switch on. Locate one of the ON/OFF switches for the conveyor and press the green ON button when ready to start the conveyor.
- 6) If necessary, the speed of the conveyor can be adjusted via the potentiometer on the DC Variable Speed Drive located at the base end of the conveyor.
- 7) The conveyor is now ready for its intended use and packages can be placed on the conveyor.

NOTE

Rollers will begin to move as soon as the ON button is pressed. If step 2 was not followed, the rollers will turn on as soon as the disconnect is turned to ON

CONNECTING CONVEYOR 3

Load Accumulation Mode: Option For "F" Model Units

(3) Powered Flex Conveyors can be connected together and run in either Accumulation Mode or Transportation Mode depending on the flow of packages.

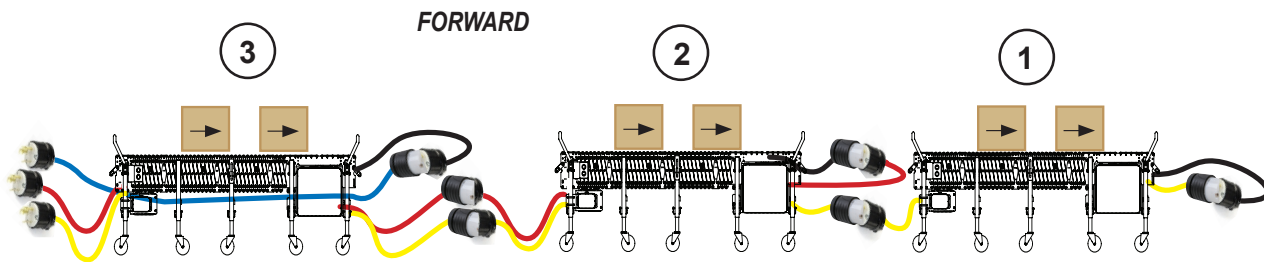

Figure 18: (3) Powered Flex Conveyors connected, load accumulation mode

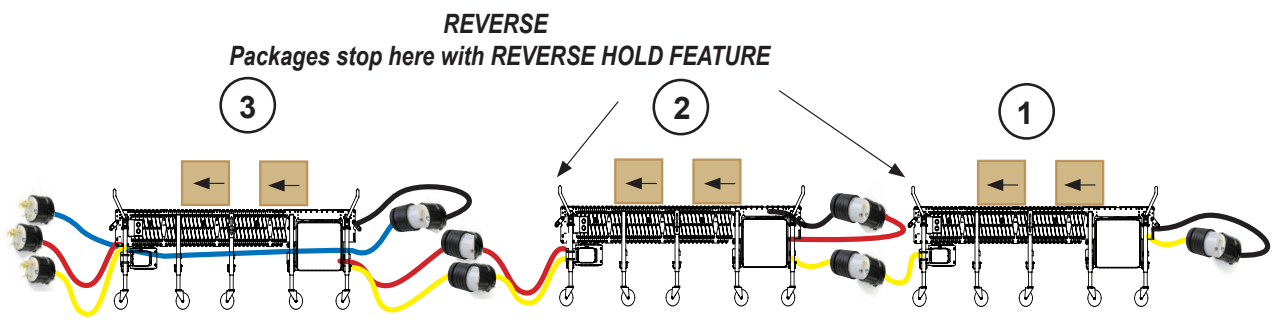

Figure 19: (3) Powered Flex conveyors connected, REVERSE, unload transportation mode

NOTE

Some conveyor models include a Reverse Hold feature which will result in packages stopping at the end of Conveyor 1 and 2.

- 1) Locate the unmarked power cable with L5-30P plug on conveyor 1 (the conveyor closest to the loading dock door) and plug it in to the Yellow marked, 10/3 SJOOW pass through power cable L5-30R receptacle flush with the conveyor 1 discharge end.
- 2) Plug the Yellow marked cable with L5-30P plug on the infeed end of conveyor 1 into the Yellow marked, 10/3 SJOOW pass through power cable L5-30R receptacle flush with the discharge end of conveyor 2.
- 3) Locate the unmarked power cable with L5-30P plug on conveyor 2 and plug it in to the Red marked, 10/3 SJOOW pass through power cable L5-30R receptacle flush with the conveyor 2 discharge end.
- 4) Locate the unmarked power cable with L5-30P plug on conveyor 3 (the conveyor farthest from the dock door) and plug it in to the Blue marked, 10/3 SJOOW pass through power cable L5-30R receptacle flush with the conveyor 3 discharge end.
- 4) Plug the Yellow marked, Blue marked and Red marked 10/3 SJOOW pass through power cable L5-30 plugs at the infeed end of conveyor 3 into individual L5-30R receptacles so that each conveyor has power that is grounded.
- 5) Ensure the Yellow, 6-pin Turck cable is connected between the discharge end and the infeed end of each conveyor to allow communication.
- 6) To start the conveyor, locate the base end with power supply enclosure and turn the Disconnect switch to the ON position. Locate the ON/OFF switches for the conveyor. When ready to START, press the green ON button.
- 7) If necessary, the speed of the conveyor can be adjusted via the potentiometer on the DC Variable Speed Drive located at the base end of the conveyor.
- 8) The conveyor is now ready for its intended use and packages can be placed on the conveyor.

NOTE

Rollers will begin to move as soon as the ON button is pressed. If step 2 was not followed, the rollers will turn on as soon as the disconnect is turned to ON

SINGLE CONVEYOR CONNECTION

A single conveyor may be powered from the opposite end of the power supply enclosure by utilizing the Blue marked pass through power cable.

- 1) Ensure the Disconnect switch is in the OFF position. Locate the unmarked power cable with L5-30P plug on the discharge end and plug it in to the Blue marked power cable L5-30R receptacle.
- 2) Plug the Blue marked power cable L5-30P plug at the infeed end of the Flex into an individual L5-30R receptacle so that the conveyor has grounded power.
- 3) To start the conveyor, locate the base end with power supply enclosure and turn the disconnect switch on. Locate one of the ON/OFF switches for the conveyor and press the green ON button when ready to start the conveyor.
- 4) If necessary, the speed of the conveyor can be adjusted via the potentiometer on the DC Variable Speed Drive located at the base end of the conveyor.
- 5) The conveyor is now ready for its intended use and packages can be placed on the conveyor.

NOTE

Conveyors powered using the BLUE pass through cable cannot be powered in series unless built to order for Load Accumulation.

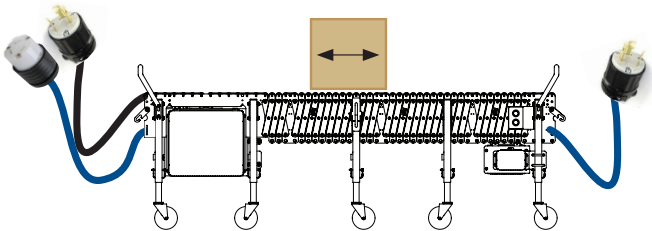

Figure 20: (1) Powered Flex Conveyor powered from opposite end

COMMUNICATION CONNECTION

Connecting Accumulation Style Powered Flex Conveyors

The Accumulation Style Powered Flex Conveyor comes with a basic interface kit. The basic kit includes everything needed for interfacing another Accumulation Style Powered Flex Conveyor.

Voltage	
Powered Flex Conveyor	Interface kit
24VDC	110VAC or 24VDC; dry contacts/relays provided

Relays

The relays communicate using Ready-To-Receive (RTR) and Ready-To-Send (RTS) protocols between conveyors.

NOTE

Interface kit schematics are available. Please consult the factory for more information.

The Accumulation Style Powered Flex Conveyor is equipped with a yellow Turck mini-connector at each end of the conveyor.



Figure 22: Discharge connector, male pin connection



Figure 21: Powered Flex Conveyor, discharge end



Figure 23: Infeed connector, female pin connection



Figure 24: Powered Flex Conveyor, infeed end

To connect the controls of (2) Accumulation Style Powered Flex Conveyors, simply connect the male connector of one conveyor to the female connector of the other. Ref. Figure 25.



Figure 21: Connected Powered Flex Conveyors

The conveyors are now enabled to communicate in accumulation mode.

Connecting the Powered Flex Conveyor to a Different Accumulating Brand Conveyor

If another manufacturer's interface is not compatible with the existing interface kit, an optional interface kit can be purchased.

NOTE

Contact the factory for further assistance or questions regarding the interface connection options available; improper connection could impact the equipment warranty.

OPERATING INSTRUCTIONS



WARNING

Conveyor must be installed in accordance with all local, city, state and national code. Make certain that all uninvolved personnel are clear of the working area.

Prior to operating the conveyor be sure to follow all inspecting, installing, and connecting instructions.

NOTE

Do not exceed the rated capacity of the conveyor 50 lbs (22.5 kg) per linear foot. Overloading the conveyor could cause damage to the conveyor or components and could void the equipment warranty.

Moving the conveyor

When maneuvering the Powered Flex Conveyor into position, always use the yellow handles attached to the legs of the conveyor or the end handles. When using the end handles, ensure that the handle is fully seated into position prior to applying force. Apply horizontal or slightly downward force to move the conveyor. Do not use an upward force.

Once the conveyor has been extended and positioned as desired, lock the caster brakes to maintain that position. As loading progresses, release the brakes to reposition the conveyor as needed.

NOTE

Keep all persons and objects away from the scissor sidebars to avoid pinch points.

Expanding the conveyor

Expand the Powered Flex Conveyor using the yellow handles attached to the legs of the conveyor or the end handles. When using the end handles, ensure that the handle is fully seated into position prior to applying force. Apply horizontal or slightly downward force to move the conveyor. Do not use an upward force.

Once the conveyor has been expanded and positioned as desired, lock the caster brakes to maintain that position. As loading progresses, release the brakes to reposition the conveyor as needed.

NOTE

Do not over stretch the conveyor beyond the natural limit. Over stretching can result in loosening or disconnection of power or communication cables. If the conveyor has been over stretched and caused loose cable connections, DO NOT operate the conveyor. Contact maintenance for repair.

Collapsing the conveyor

Collapse the Powered Flex Conveyor using the yellow handles attached to the legs of the conveyor or the end handles. When using the end handles, ensure that the handle is fully seated into position prior to applying force. Apply horizontal or slightly downward force to move the conveyor. Do not use an upward force.

When collapsing the conveyor, allow the conveyor to be in a relaxed state. Avoid tightly compressing the conveyor such that the rollers come into contact with each other.

Bending the conveyor

Bend the Powered Flex Conveyor using the yellow handles attached to the legs of the conveyor or the end handles. When using the end handles, ensure that the handle is fully seated into position prior to applying force. Apply horizontal or slightly downward force to move the conveyor. Do not use an upward force.

When flexing the conveyor into curved formations, allow the conveyor to bend naturally. Do not force the conveyor into curves that place stress on the sidebars or cause the rollers to touch at the inside of the curve.

NOTE

Impact loading or dropping packages is not recommended for the Powered Flex Conveyor and can cause damage to the conveyor and/or its components that could void the equipment warranty.

Package movement

Accumulation style conveyors are designed to move products forward when the downstream zone is clear. If the downstream zone is clear and the product is not moving, do not attempt to push the product downstream. Alert a maintenance technician.

Transportation style conveyors are designed to constantly convey products downstream. If the conveyor is clear and the product is not moving, do not attempt to push the product. Alert a maintenance technician.

NOTE

Manually pushing products is not recommended for the conveyor and could cause damage to the conveyor that could void the equipment warranty.

GENERAL PREVENTATIVE MAINTENANCE

Periodic maintenance intervals shown may vary with load, speed, hours of daily operation, ambient temperature, humidity, etc. Intervals can be established by fairly frequent maintenance at first; then lengthen the intervals as justified by observation of need based on history. The following is based on 5 days per week, 8 hours per day under normal conditions.



WARNING

- **Prohibit riding on conveyor by anyone.**
- **Think before making any adjustments. It may prevent an injury. Remember, all moving components are potentially dangerous.**
- **Protect yourself from unexpected starts when working on a stopped unit by locking the control panel or disconnect switch that supplies power to the unit.**
- **Lockout/Tagout procedures must be followed for every energy source of the conveyor.**

Follow general maintenance safety procedures and review safety material prior to performing maintenance on any equipment.

Regular inspections are recommended by the manufacturer for the Powered Flex Conveyor to ensure proper operation of mechanical, electrical, and safety systems.

DAILY MAINTENANCE

- Listen to everything for unusual noises or vibration.
- Visually inspect to see that Conveyor sections are clear and free of debris.
- Inspect wires and cables for damage.
- Inspect belts for wear.
- Inspect casters and caster mount tubes for damage or missing parts.
- Inspect for loose fasteners or missing parts.
- Verify all Start/Stop push-buttons operate properly.
- Inspect side bars to make sure side bars are not bent. Replace side bars as needed.

WEEKLY MAINTENANCE

- Check all warning labels are still legible and properly placed.
- Check for unrestrained/pinched wiring, loose wiring connectors, nip points and other hazards.
- Check Mech-Drive Controller drive card for any warning lights.
- Check ends of photo eye sensors for damage and proper location.
- Check roller screws are tightened, replace any missing screws.

MONTHLY MAINTENANCE

- Check for consistent belt tension between rollers.
- Verify drive sheave set screws are tight.

QUARTERLY MAINTENANCE

- Check motor and ensure that motor is operating within its proper heat and noise range and verify the motor card does not indicate a problem.
- Check controller has power.
- Check controller does not show errors.

Photo Eye Sensors

Photo eye sensors can be damaged or dislocated due to side loading and other operational activities where product being loaded/unloaded on the Conveyor comes in direct contact with the sensors. These types of activities should be avoided to prevent damage to the Conveyor's normal operation. However, the photo eyes should be inspected on a weekly basis, or more often depending on the hours in service, to prevent further damage or interruption to the Conveyor's operation.

- Check photo eyes for damage and/or dislocation.
- If damaged, replace as needed.
- If dislocated, reposition to normal operating position and secure in place.

Controller

Controller can be damaged or have loose connection from improper movement or tension to the wiring/cabbling through movement of the Conveyor. Motor cards should be routinely checked for proper power and errors.

- Inspect the motor cards.
- Check wiring and ensure proper contact with the driver card pins.
- Loosen or tighten wires as needed. Follow procedures for cabling wires.
- Repair and/or replace any driver cards with errors.

GENERAL TROUBLESHOOTING

PROBLEM	CAUSE	SOLUTION
None of the zones will run	Power supply if off	Turn on power supply
	Power supply is not receiving AC power	Check AC power
	AC power fuse is blown or breaker is tripped	Replace fuse, check breaker
	Power supply breaker is tripped	Check power supply breaker
	No power to flat motor ZPA module	Check output power of power supply
	Power supply voltage too high or too low	Check output voltage of power supply
Entry zone will not turn on	Missing wake-up zone photo-eye	Add wake-up photo-eye
	Entry zone photo-eye not aligned properly	Check wake-up photo-eye alignment
	Missing/incorrect handshaking wiring	Check handshaking wiring
	Incorrect DIP switch setting	Check DIP switches
	No power to ZPA module	Check power connections
	Motor cable not connected to ZPA module	Check motor connections
Transport zone will not turn on	Communication wiring missing or not plugged in	Check upstream and downstream communication wiring
	Photo-eye is blocked or misaligned	Check photo-eye and reflector
	Incorrect DIP switch setting	Check DIP switches
	No power to ZPA module	Check power connections
	Motor cable not connected to ZPA module	Check motor connections
Transport zone will not turn off	Upstream zone is attempting to send product	Check photo-eye alignment in upstream zone
	Upstream zone is attempting to send product	Check for jammed product in upstream zone
Entry zone or transport zone will not discharge product	Communication wiring missing or not plugged in	Check communication wiring
	Downstream zone is full	Remove product from downstream zone
	Downstream zone photo-eye not aligned properly	Check downstream photo-eye
Exit zone will not discharge product	Incorrect handshaking wiring	Check handshaking wiring
	Downstream device not sending a release signal	Check downstream device output signals
	DIP switch not configured properly	Check DIP switches

CONTROLLER TECHNICAL INFORMATION

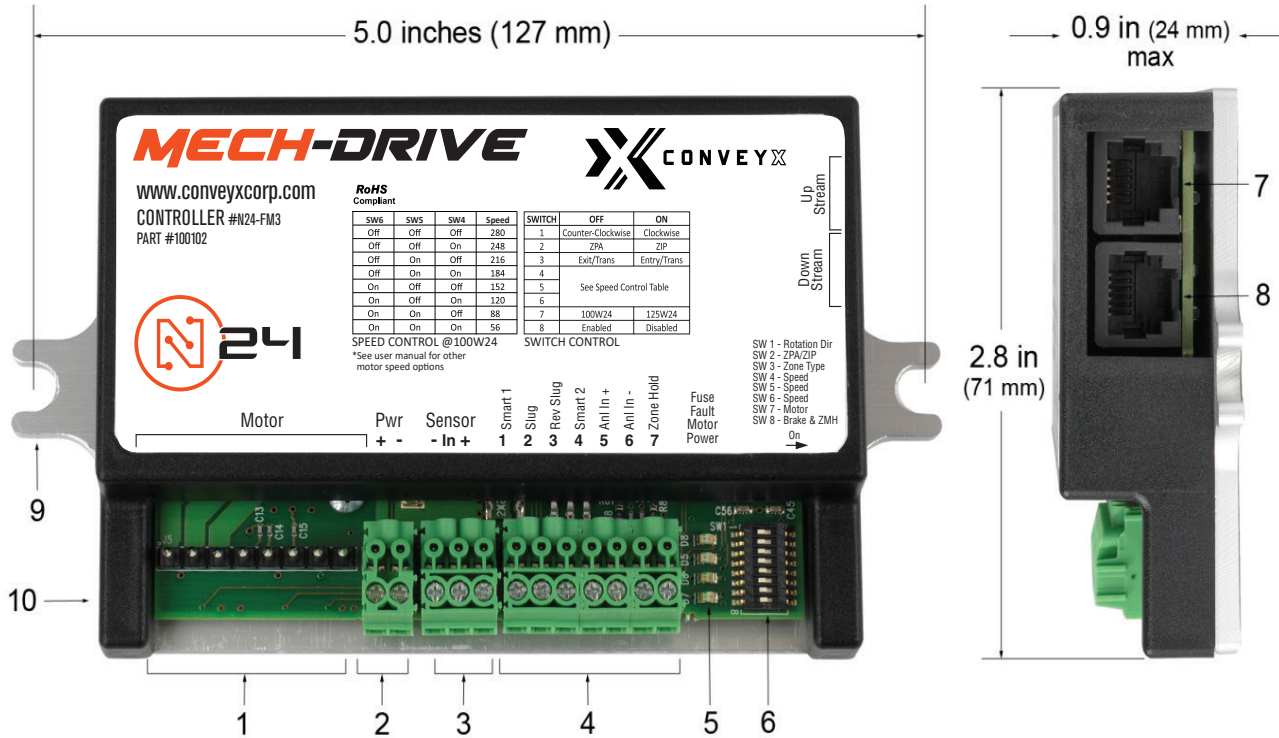

Figure 26: MECH-DRIVE N24-FM3 Controller Components

Reference Mech-Drive Drawing	Description
1	Motor Connection Header
2	+24VDC Power Input Header (plug included)
3	PNP Sensor Connection Header (plug included)
4	Smart/User Input-Output Connection Header (plug included)
5	Feedback LED Indicators
6	Configuration Switches
7	Upstream Peer-to-Peer PNP RJ-12 Connection
8	Downstream Peer-to-Peer PNP RJ-12 Connection
9	Mounting Plate/Heat Sink
10	Cover

Default Dip Switch Settings

Accumulation Style Conveyor	
Infeed Zone Card	SW 2 and SW 3 are ON
All other cards	SW 2 is ON

Transportation Style Conveyor	
All cards	SW 2 is ON

80' Accumulation Style Conveyor	
Infeed Zone Card	SW 1, SW 2, and SW 3 are ON
All other cards	SW 2 is ON

TROUBLESHOOTING: CONTROLLER

The Mech-Drive N24-FM3 provides four (4) LED indicators shown as item 5 in Figure 22: Mech-Drive N24-FM3 Controller Components. These LEDs are often useful in diagnosing various wiring and connection problems. If power is connected there will always be at least one LED illuminated or flashing.

PROBLEM	CAUSE	SOLUTION
No LED's On	No power to the system	Check power supply
FUSE LED (RED) is On	Fuse is blown	Check wiring Replace fuse
FAULT LED 5.1 (RED) - Constantly On	Stalled motor or blocked photoeye	Check for mechanical obstructions
FAULT LED 5.1 (RED) - 1 Flash in 4 Seconds	ZPA module problem	Replace ZPA module
FAULT LED 5.1 (RED) - 2 Flashes in 4 Seconds	Input voltage too high	Check power supply
FAULT LED 5.1 (RED) - 3 Flashes in 4 Seconds	Input voltage too low	Check power supply
FAULT LED 5.1 (RED) - 4 Flashes in 4 Seconds	Problem with motor cable connection	Check motor cable for damage and secure connection to ZPA module
FAULT LED 5.1 (RED) - 5 Flashes in 4 Seconds	Control over temperature	Allow card to cool. Check for ambient temperature and heat sources. Check for proper motor function and wiring. Cycle power to reset.
FAULT LED 5.1 (RED) - 6 Flashes in 4 Seconds	Extreme over current	Check for proper motor function and damaged wiring. Allow unit to cool. Cycle power to reset.
MOTOR LED 5.2 (AMBER) - Constantly On	ZPA module is current limiting the flat motor	If condition persists, check for obstructions
MOTOR LED 5.2 (AMBER) - Flickering	Flat motor is drawing significant current during startup, ZPA module is current limiting	No action required Motor may not reach full speed
MOTOR LED 5.2 (AMBER) - 4 Flashes in 4 Seconds	ZPA module has overheated and current limiting the flat motor to about 1/2 normal operation	Check for mechanical obstruction Allow ZPA module to cool, before restarting
POWER LED 5.3 (GREEN) - Constantly On	Power is properly applied and fuse is not blown	Normal operation

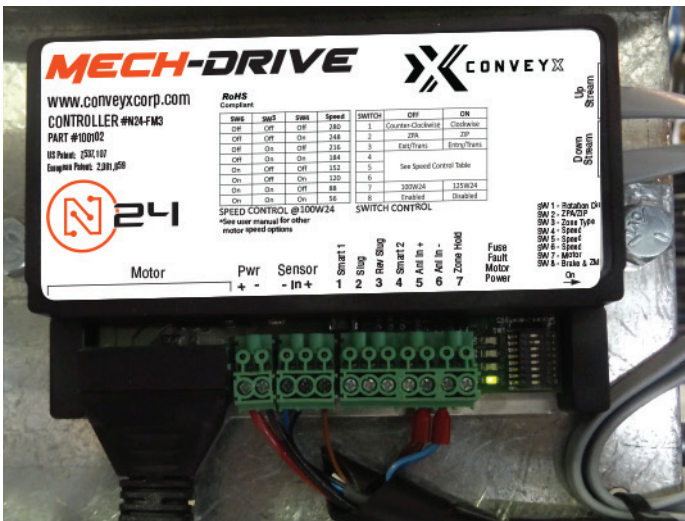

Figure 27: Mech-Drive Controller wiring and lights during normal operation.



Figure 28: 40 amp Power Supply with power applied during normal operation.

NOTE

If not lit up green, power is not applied to the conveyor:

1. Check to be sure disconnect is in the ON position
2. Check Start/Stop buttons
3. Check power source
4. The power cable for the conveyor should be disconnected from the power receptacle and then check for loose wires inside the enclosure or tripped breakers.

WARRANTY STATEMENT

The Seller warrants that the Equipment will be free of defects in workmanship and material (if properly installed, operated and maintained) for a period of one year or 2080 hours of use, whichever is sooner, from date of shipment to Customer, subject to the limitations hereunder set forth. If within the one year warranty period, the Seller receives from the Customer written notice of any alleged defects in the Equipment and if the Equipment is not found to be in conformity with this warranty (the Customer having provided the Seller a reasonable opportunity to perform any appropriate tests thereon) Seller will, at its option, either repair the Equipment or supply a replacement therefore.

The Seller under either option shall have the right to require Customer to deliver the Equipment to Seller's designated service center and the Customer shall pay all charges for in-bound and out-bound transportation and for services of any kind, diagnostic or otherwise, excepting only the direct and actual costs of repairing or replacing the Equipment. If after reasonable effort the Seller cannot correct said deficiencies, the Seller will make an equitable price adjustment based on actual performance, provided that such adjustment shall under no circumstances exceed the purchase price. The Seller further warrants that the parts, and components supplied by the Seller and forming a part of the Equipment will be free from defects in material and workmanship for a period of one year or 2080 hours of use, whichever is sooner, from date of shipment to the Customer. The Seller's liability shall be solely limited to the supplying of replacement parts and materials.

For a copy our full warranty included in our Terms and Conditions of Sale, contact Ultimation Industries, LLC.

RETURN AUTHORIZATION PROCEDURES

If the component in question is included in the replacement parts package, the following procedure will apply:

- Identify the part number from the manual
- If part is indicated as wear part
 - Replace the damaged or defective part from parts inventory
 - Order additional parts as required
- If the part is indicated as a warranty part
 - Replace the damaged or defective part from parts inventory
 - Contact Ultimation for a Return Merchandise Authorization (RMA) number
 - Have conveyor serial number available when contacting Ultimation.
 - Send the part to the following address
 Ultimation Industries LLC
 15935 Sturgeon St,
 Roseville, MI 48066
- Include the conveyor serial number and RMA number on the packaging and the packing slip
- Ultimation will inspect the part and make a warranty determination
- If the part is under warranty, Ultimation will...
 - Ship a replacement to Customer to replenish parts stock
 - Issue a credit for the freight

If the component in question is not included in the replacement parts package, the following procedure will apply:

- Identify the part number from the manual
- Contact Ultimation for an initial review to establish if part is covered under warranty and to provide a quote if needed.
- Have conveyor serial number available when contacting Ultimation
- Issue a purchase order for a replacement part
- Ultimation will issue a Return Merchandise Authorization (RMA) number for the part to be returned.
- Send the part to the following address
 Ultimation Industries LLC
 15935 Sturgeon St,
 Roseville, MI 48066
- Include the conveyor serial number and RMA number on the packaging and the packing slip
- Ultimation will inspect the part and make a warranty determination
- If the part is under warranty, Ultimation will Issue a credit to Customer for the purchased part and associated freight charges

PARTS REFERENCE CHART AND DRAWINGS

(note: parts list for standard 1.4" roller, 30" BF, some parts may vary, consult factory)

POWERED FLEX CONVEYOR WEAR/REPLACEMENT PARTS		
A	LW038	LOCK WASHER: 3/8, ZINC PLATED
B	FW014	FLAT WASHER: 1/4, ZINC PLATED
C	FW0516	FLAT WASHER: 5/16, ZINC PLATED
D	LW0516	LOCK WASHER: 5/16, ZINC PLATED
E	NLN051618	LOCK NUT (NYLON): 5/16-18, ZINC PLATED
F	NLN03816	LOCK NUT (NYLON): 3/8-16, ZINC PLATED
G	SHSSOV01420X038	SET SCREW (SOCKET HEAD)(OVAL POINT): 1/4-20 X 3/8, BLACK OXIDE, CASE HARDENED
H	SHSS038X114	SOCKET HEAD SHOULDER SCREW: 3/8 DIA. SHOULDER X 1 1/4 LONG, 5/16-18 THREAD, BLACK OXIDE, CASE HARDENED
J	SHSSCUK0140X038	SET SCREW(SOCKET HEAD)(CUP POINT): 1/4-20 X 3/8, BLACK OXIDE, CASE HARDENED, KNURLED
K	BHSCS1024X012	BUTTON HEAD SOCKET CAP SCREW: #10-24 X 1/2" LONG, BLACK OXIDE, CASE HARDENED
L	FXDS-V1	SHEAVE (DRIVE): 2-5/8" HUB OD, 1/2" BORE, 1.250" LTB, W/(2) NARROW GROOVES ON 5/8" C/C
M	FXLG-CU-V1	LEG TUBE UPRIGHT: INNER
N	FXLG-LW-EH-30-V1	END LEG WELDMENT: 30" BF
P	FXLS	SHEAVE ASSEMBLY: LONG HEX
Q	FXRO-D-30	GROOVED ROLLER: 1 3/8" DIA X 18 GA. GALV, 30" BF, FLO-COAT, 5/16 FIXED HEX AXLE DRILLED AND TAPPED, #116157-O BEARINGS, 2 GROOVES (ONE EACH END)
R	FXSB-D-V1	BRACKET: DOUBLE VERTICAL FOR PHOTO EYE
S	FXSB-S	SCISSOR PLATE
T	FXSB-V	BRACKET: VERTICAL
U	FXUH-3S	UHMW SPACER: 3/16 (BLACK)
V	FXUH-6S	UHMW SPACER: 3/8 (BLACK)
W	FXUH-W	UHMW WASHER: 0.057 THICK (BLACK)
X	CXC-100010	CABLE (COMMUNICATION): RJ-12, FLAT SILVER SATIN, 6P6C, REVERSE PINOUT, 7 FT
Y	AMPP30814	CABLE (SINGLE DROP): FOR 36" ZONE, M22 CONNECTORS, 12 AWG TRUNK, 18 AWG DROP, 2 CONDUCTOR
Z	FXST-SA-30-V2	ROLLER SENSOR SUB ASSEMBLY: 30" BF, SHORTER SENSOR (FOR 2018 MODEL OR NEWER POWERED FLEX)

POWERED FLEX CONVEYOR WEAR/REPLACEMENT PARTS		
AA	CXC-100012	ROUND BELT: 3/16" DIA. X 6-1/4" LONG, CYCLOTHANE-B 85A DUROMETER, HIGH TENSION BLUE, WELDED LOOP
BB	CXC-100013	ROUND BELT: 3/16" DIA. X 11-15/16" LONG, CYCLOTHANE-B 85A DUROMETER, HIGH TENSION BLUE, WELDED LOOP
CC	CXC-100014	ROUND BELT: 3/16" DIA. X 12-3/4" LONG, CYCLOTHANE-B 85A DUROMETER, HIGH TENSION RED, WELDED LOOP
DD	CXC-100100	MTR (BRUSHLESS DC FLAT): 24VDC, 4.0 AMP
EE	FAS0120680	LOCKING PIN: 1/4" DIAMETER PIN, 2 1/2" USEABLE LENGTH, 2 1/2" RETAINER CLEARANCE, ZINC PLATED STEEL, LOCKING RETAINER W/EASY RELEASE TAB
FF	CXC-100102	DRIVER CARD (24V DC): MECH-DRIVE N24-FM3 - ASSEMBLY
GG	CXC-100055B	CASTER (SWIVEL W/BRAKE): 5" X 1 1/4" RUBBER WHEEL, 1/2-13 THRD X 2-3/4" L. LOCKING STEM
HH	CXC-100055	CASTER (SWIVEL): 5" X 1 1/4" RUBBER WHEEL, 1/2-13 THRD X 2 3/4" L. LOCKING STEM
JJ	SHSS012X2	SOCKET HEAD SHOULDER SCREW: 1/2" DIA. SHOULDER X 2" LONG, 3/8-16 THREAD, BLACK OXIDE, CASE HARDENED
KK	SHSS038X058	SOCKET HEAD SHOULDER SCREW: 3/8" DIA. SHOULDER X 5/8" LONG, 5/16-18 THREAD, BLACK OXIDE, CASE HARDENED
LL	SHSS038X2	SOCKET HEAD SHOULDER SCREW: 3/8" DIA. SHOULDER X 2" LONG, 5/16-18 THREAD, BLACK OXIDE, CASE HARDENED
MM	SHSSCU632X0332	SET SCREW (SOCKET HEAD)(CUP POINT): #6-32 X 3/32, BLACK OXIDE, CASE HARDENED
NN	PHO1984015	TERMINAL BLOCK: PT 1,5/ 2-PVH-3,5, 2 PIN PLUG, SCREW CONNECTIONS, 8 AMP
PP	PHO1984028	TERMINAL BLOCK: PT 1,5/ 3-PVH-3,5, 3 PIN PLUG, SCREW CONNECTIONS, 8 AMP
QQ	PHO1984060	TERMINAL BLOCK: PT 1,5/ 7-PVH-3,5, 7 PIN PLUG, SCREW CONNECTIONS, 8 AMP
RR	NLN01420	LOCK NUT (NYLON): 1/4-20, ZINC PLATED
SS	CXC-100025	BRIDLE RING W/SADDLE: 2" DIA LOOP, 1/4-20 THREADED STUD, 50# LOAD
TT	HJN501420	JAM NUT (HEX): 1/4-20, GRADE 5, ZINC PLATED
UU	SHSS038X038	SOCKET HEAD SHOULDER SCREW: 3/8" DIA. SHOULDER X 3/8" LONG, 5/16-18 THREAD, BLACK OXIDE, CASE HARDENED

***SEE SALES REP FOR AVAILABLE PARTS PACKAGES.**

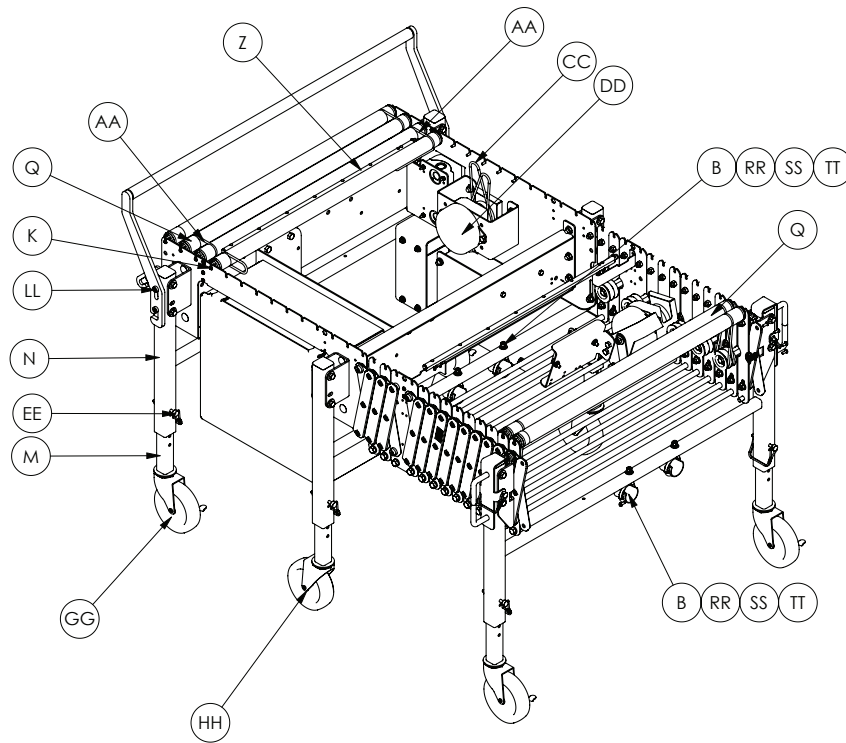

Powered Flex Conveyor assembly

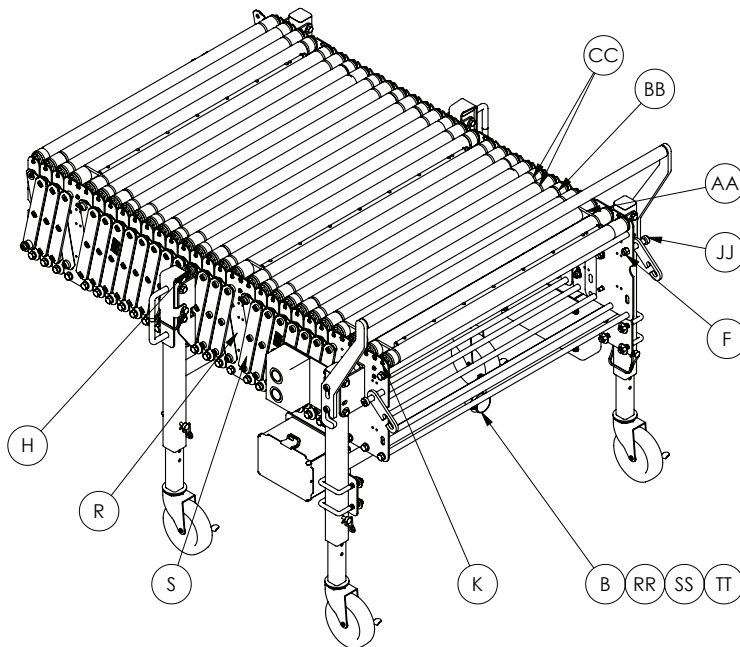

Powered Flex Conveyor sub-assembly

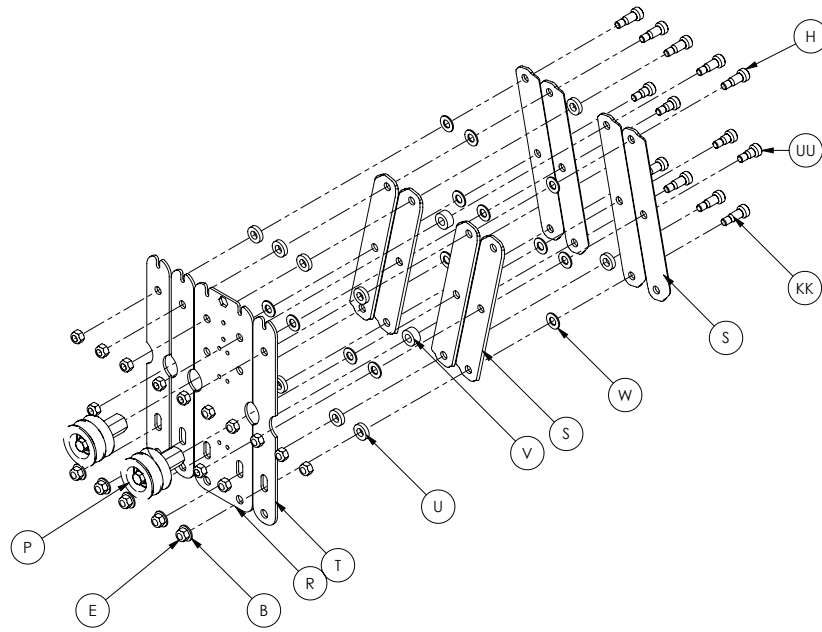

Side link assembly

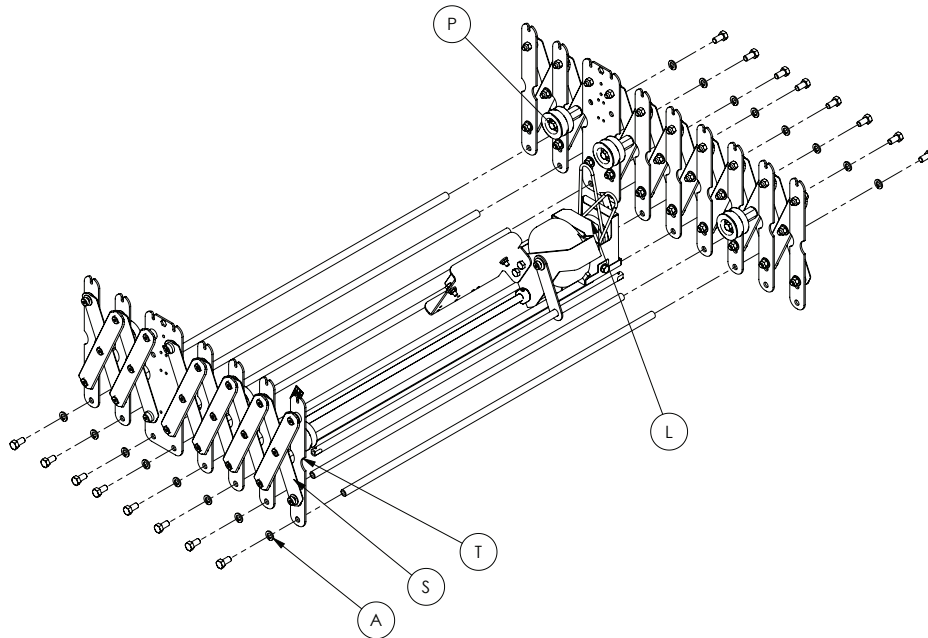

Side link and drive motor assembly



Drive motor view 1

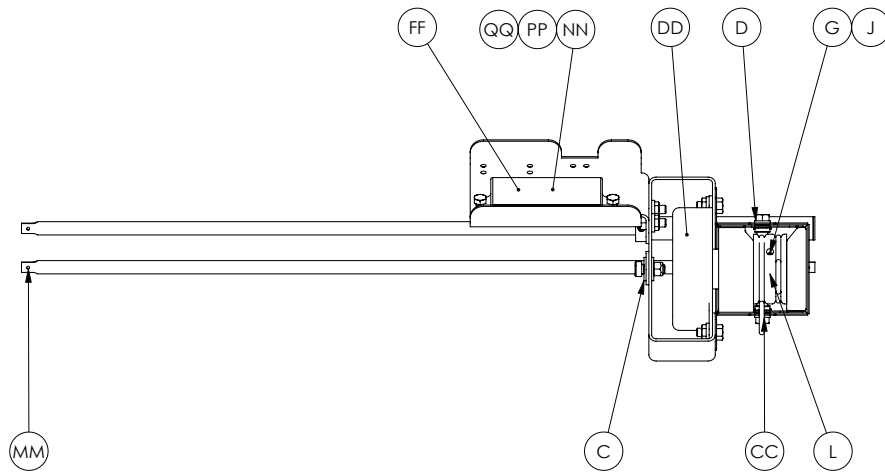

Drive motor view 2

Ultimation strives to be the leading dock door conveyor solutions manufacturer in North America. Our load and unload material handling equipment is designed for unit handling applications delivering operational improvements and energy efficiency.

We build to our customers' specifications to enhance their processes with quality equipment and components. We specialize in rapid product development to exceed lead time and volume requirements.