

Company name: \_\_\_\_\_

Contact person: \_\_\_\_\_

E-mail: \_\_\_\_\_

Telephone no.: \_\_\_\_\_

Product specifications + Lay-out: Send to [rfqdesk@ultimation.net](mailto:rfqdesk@ultimation.net)

Remarks: \_\_\_\_\_

\_\_\_\_\_

\_\_\_\_\_

\_\_\_\_\_

\_\_\_\_\_

\_\_\_\_\_

Drawing: \_\_\_\_\_

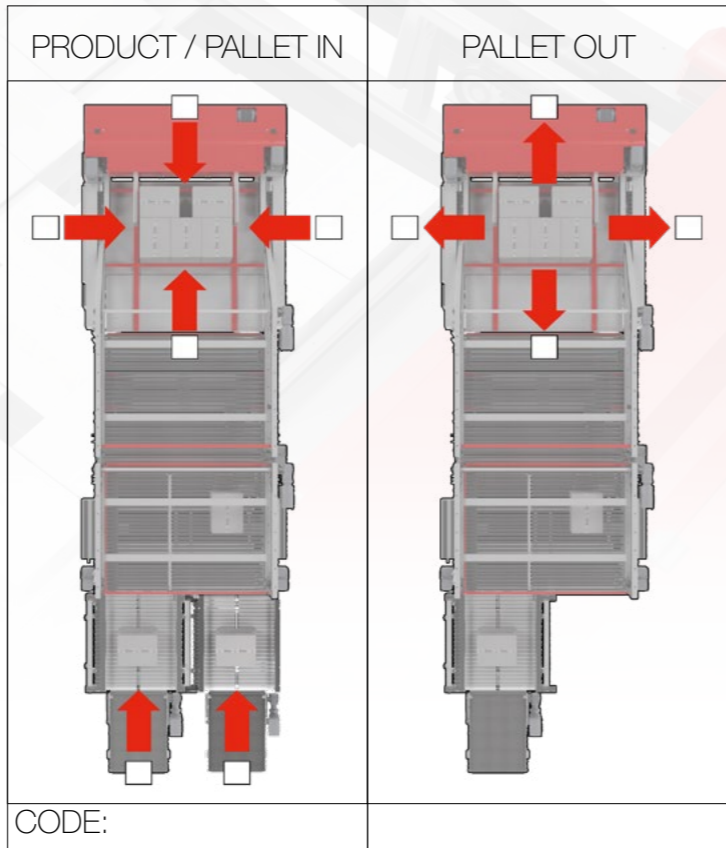
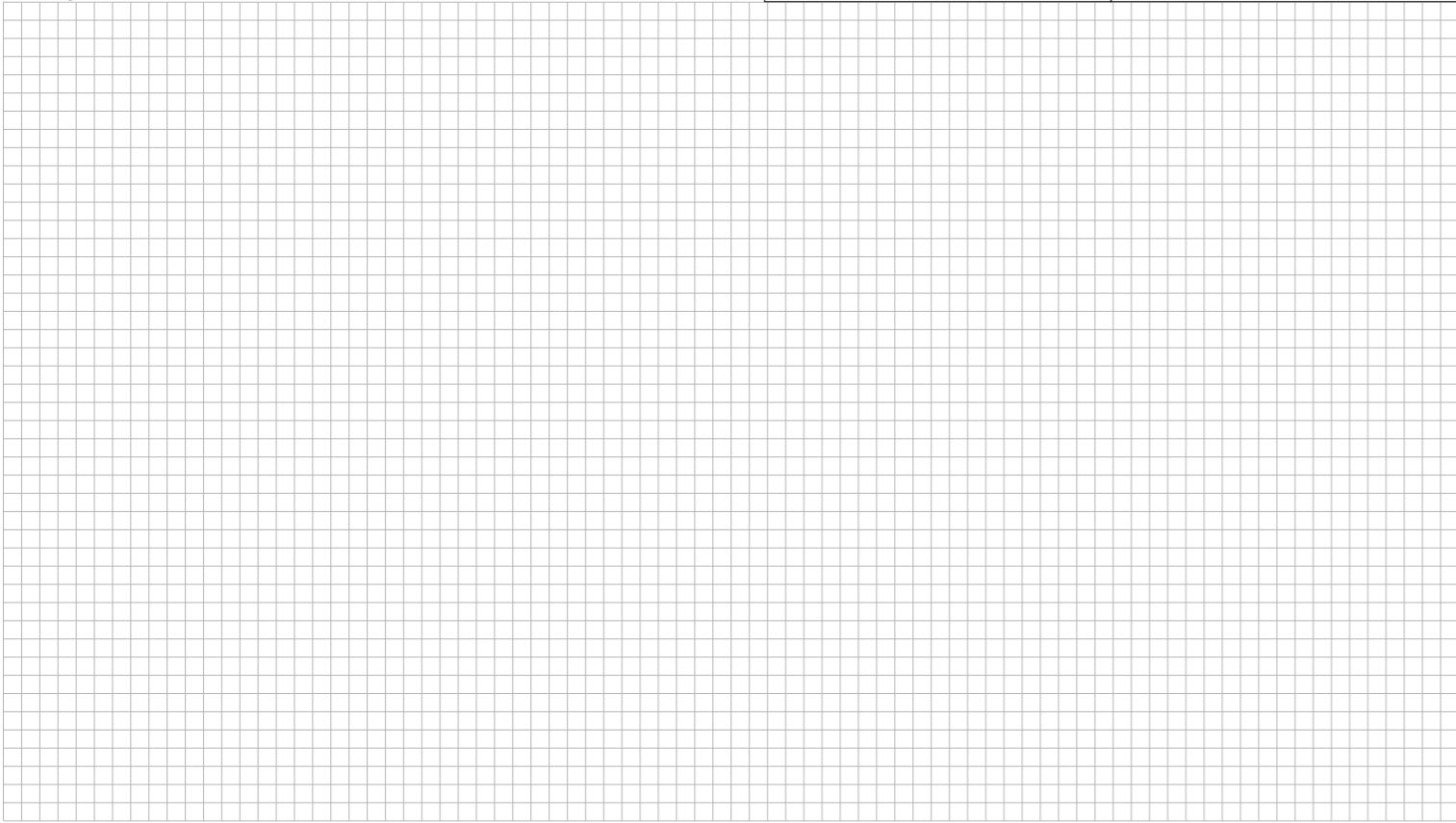

# HIGHRUNNER HR9 LOGISTICS PALLETIZER

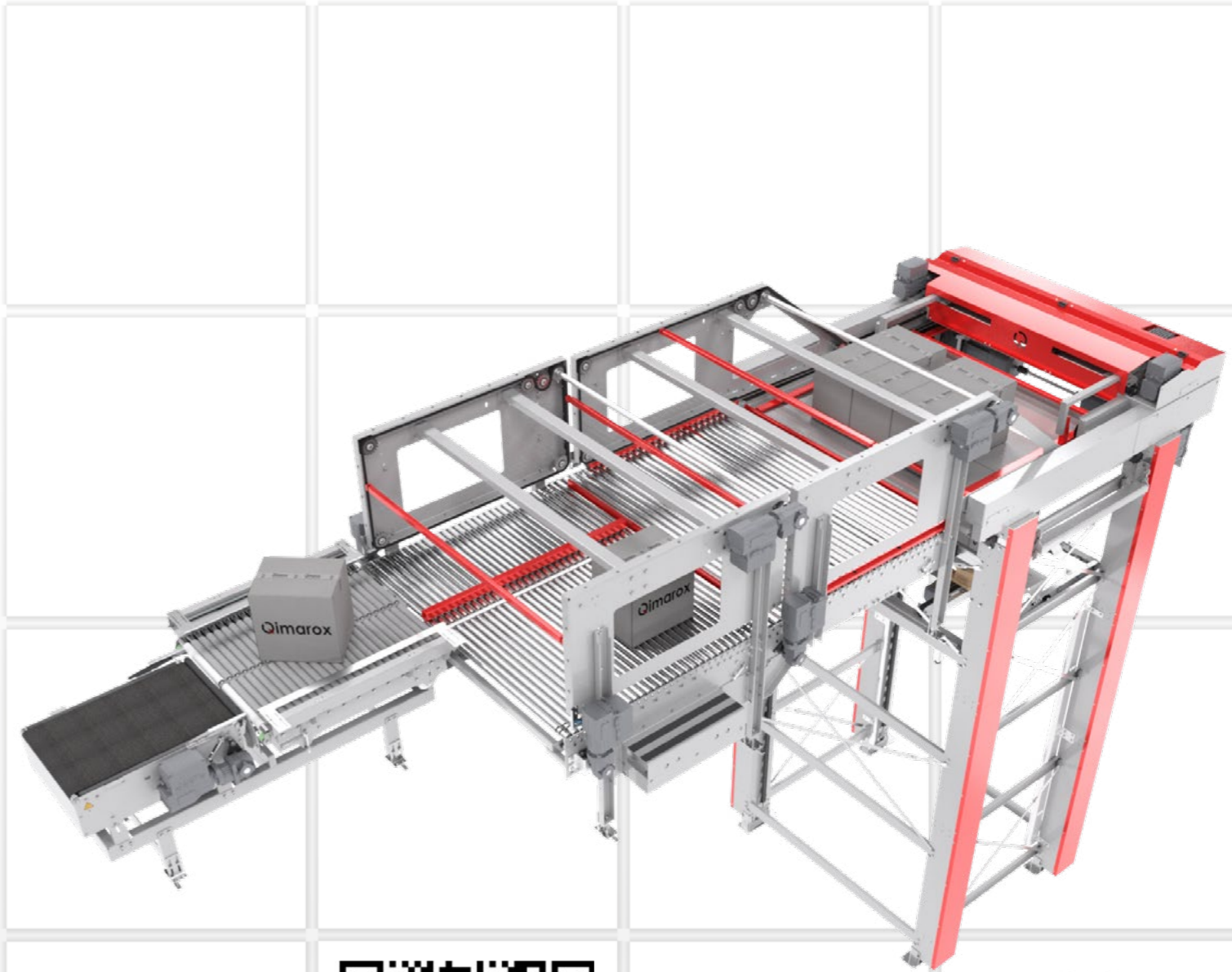

**BOOK AN ONLINE DEMONSTRATION**  
AND FIND OUT WHAT OUR COMPONENTS CAN DO FOR YOUR MATERIAL HANDLING



Disclaimer: This document is for informational en promotional purposes only.  
All orders are subject to the Qimarox terms and conditions and Qimarox's written confirmation. Copyright © 2024v3 Qimarox

Nobelstraat 43 NL-3846 CE Harderwijk The Netherlands Tel +31 341 - 436 700 USA Toll Free 877 778 83 75 [sales@Qimarox.com](mailto:sales@Qimarox.com)  
[www.Qimarox.com](http://www.Qimarox.com)

Key Components for material handling:

- Vertical Conveyors • Palletizing Modules • Sorting & Buffering • Pallet Stackers • Safety Fencing

### Advantages of the Highrunner HR9

- Unique method of pattern formation, where products are positioned on exact coordinates (patented)
- Prorunner PRmk10 pallet lift
- Built-in buffer for depositing products in layers
- User-friendly touchscreen operation (Pack ML)
- Freely programmable stacking patterns
- Solid construction with perfect finishing for tough jobs
- Easy access for service and maintenance
- Standard machine with commercially available components
- Infeed height adjustable in steps of 9.84 inch
- Max. product length 31.50 inch - Condition: only straight infeed

Specifications		Qimarox - Highrunner HR9
Infeed height at platform level ■	inch	24 - 39
Product dimensions ◀	L x W x H inch	8 x 8 x 6 - 24 x 16 x 24
Throughput product *	p/hour	500 - 1500
Throughput layers	p/hour	300
Product weight/ layer weight	lb	55 / 400
Footprint	sq ft²	80 (at ground floor)

\* Throughput depends on pattern and product dimensions



	Layers 	
		Products 



Key Components for material handling:

- Vertical Conveyors • Palletizing Modules • Sorting & Buffering • Pallet Stackers • Safety Fencing



Key Components for material handling:

- Vertical Conveyors • Palletizing Modules • Sorting & Buffering • Pallet Stackers • Safety Fencing